

Green banking practices and banking environmental performance in Saudi Arabia: A moderating effect of banking economic sustainability

Anass Hamadelneel Adow^{a*}

^aDepartment of Accounting, College of Business Administration, Prince Sattam Bin Abdulaziz University, 173 Alkharj 11942, Saudi Arabia

ABSTRACT

Article history:

Received June 3, 2024
Received in revised format July 25, 2024
Accepted August 29 2024
Available online
September 2 2024

Keywords:

Green banking practices
Banking economic sustainability
Banking environmental performance
Environmental sustainability

Green Banking Practices (GBP) would help to achieve Banking Environmental Performance (BEP). Therefore, the present research aims to find this nexus in the Saudi banking sector by applying the mediating role of Banking Economic Sustainability (BES). For this purpose, primary data was collected from 356 employees of the banking sector in Saudi Arabia, and Structural Equation Modelling (SEM) is applied for hypothesis testing. The findings disclose that GBP improves both BEP and BES and also BES enhances BEP. Thus, BES moderated the relationship between GBP and BEP. The research recommends the Saudi banking sector to further adopt environmentally sustainable practices to achieve their economic sustainability and environmental performance. Thus, the Saudi banking sector could play its role in achieving environmental sustainability in Saudi Arabia by reducing energy consumption and pollution emissions from banking operations.

© 2025 by the authors; licensee Growing Science, Canada.

1. Introduction

In the modern world, economic growth should be aimed at environmental sustainability, and the banking sector might play a vital role in achieving sustainable growth without harming the environment (Liu et al., 2020). Particularly, the banking sector should follow environmentally sustainable practices to avoid any environmental problems in banking operations and decision-making processes (Aslam & Jawaid, 2023a; Chen et al., 2024), which may be termed Green Banking Practices (GBP). Thus, the banking sector should adopt environmentally friendly practices in its operations and should also finance environmentally friendly projects to reduce Greenhouse Gas (GHG) emissions (Chowdhury et al., 2013). In this way, GBP would help reduce energy consumption and promote energy efficiency through sustainable practices in the banking sector (Ji et al., 2023), which would reduce GHG emissions from banking sector operations. Moreover, GBP can finance environmentally friendly projects and help to build renewable energy and/or energy-efficient infrastructure in the economy to reduce GHG emissions in the whole economy for compliance with environmental regulations in the country (Bose et al., 2021).

GBP would promote environmental sustainability in several ways. For instance, the banking sector may utilize energy-efficient technologies and devices in banking operations (Lekakos et al., 2014), which can reduce energy consumption from the banking sector and help in reducing GHG emissions (Gulzar et al., 2024). Moreover, the banking sector can reduce the use of paper in their official needs by switching to computers and other electronic technologies, which would reduce the pressure on paper usage to reduce the pressure on natural resources utilized in the paper industry. In this way, GBP can promote the concept of Banking Environmental Performance (BEP). Moreover, online banking technology can help in the reduction of paper (Shaumya et al., 2017) on the one hand and can reduce the banking trips of the banking customers on the other hand, which can reduce the energy consumption from transport and mitigate GHG emissions associated with traveling

* Corresponding author
E-mail address anass.hamad@gmail.com (A.H. Adow)

to visit the banks. Furthermore, the banking sector can provide educational and training programs to their employees to adopt and implement sustainable and green practices in their daily tasks (Malsha et al., 2020; Risal & Joshi, 2018). Lastly, the banking sector can promote the financing of environmentally beneficial and sustainable projects (Nawaz et al., 2020), which can develop the infrastructure for the whole economy for clean energy and energy-efficient technologies.

By adopting sustainable practices, the banking sector may also achieve Banking Economic Sustainability (BES) (Jain & Sharma, 2023), by reducing the cost of banking operations, increasing the customer base, and boosting banking profits by using the slogan of green banking and by differentiating green banking from conventional banking practices. GBP can help in paperless banking, which can reduce the cost associated with paper and printing. Moreover, using energy-efficient technologies would reduce energy bills and reduce energy costs associated with banking operations. In addition, GBP would help increase the customer base by marketing their eco-friendly banking operations and the funded eco-friendly project (Rai et al., 2019). This marketing will attract environmentally conscious clients, which will help in increasing the customer base (Majeed and Rasheed, 2024). Moreover, the marketing of the GBP to differentiate green banking would give a competitive advantage to the green banks, which will again win customer loyalty and community confidence and trust in the green banks. Thus, the green banking business may expand more than conventional banks, which might increase the revenues and market share of the green banks. Thus, reducing banking operation costs and increasing revenues and market share of the green banks can increase profits and economic sustainability of green banks. These revenues and profits may again be invested for GBP and BEP. Thus, BES may be positively moderated the relationship between GBP and BEP.

Following the above discussions, GBP can improve BEP and BES can also moderate the relationship between GBP and BEP. Thus, the present study tests these hypotheses in the Saudi banking sector. Saudi Arabia is transforming its economy from the oil sector to other cleaner sectors and also focusing the environmentally sustainable technologies and practices in the kingdom for a demand for a cleaner environment in the country. Thus, it is very important to investigate these hypotheses in the Saudi banking sector to gauge whether the Saudi banking sector is aligning with the national environmental target or not. Thus, the present research explores the impact of GBP on BEP by assuming a moderating role of BES with a particular focus on how these practices moderate the relationship between banking activities and economic sustainability. The Saudi literature has not investigated such a relationship to the best of my knowledge. Thus, the present research is claimed to be a contribution to Saudi banking literature and can provide deeper insights into the effectiveness of green initiatives in the banking sector to play its role in promoting a sustainable economy. Moreover, the results would guide banking environmental performance indicators from policy perspectives. The rest paper is structured as follows. The next section reviews the literature on Green Banking Practices and their implications for banking performance, which will be followed by a discussion of the research methodology, including data collection and analysis techniques. Later, the findings section will present the results of the empirical analysis to highlight the moderating effects of BES on the relationship between GBP and BEP. Finally, the paper concludes with a discussion of the implications of the findings to promote banking policies in favor of GBP.

2. Literature Review

GBP would help in achieving BEP, which would also help in achieving competitiveness, stock market performance, and consumer perception of the banks. Thus, GBP and Corporate Social Responsibility (CSR) would enhance consumer behavior and profit of the banks (Dincer & Dincer, 2006). Tara and Singh (2014) investigated the Indian banks emphasizing the importance of economic, social, and environmental performance and found that green loans, paperless banking, environmentally conscious investment policies, and advocating for a comprehensive approach to sustainability in the financial sector helped to achieve environmental sustainability. Thus, the authors emphasized the growing responsibility of financial institutions to adopt Environmentally Friendly Practices (EFP).

Lekakos et al. (2014) examined the effects of CSR and found a positive impact of CSR on users' attitudes. Further, the authors found the functional and sustainability attributes moderated by green e-banking services. Weber (2017) investigated the financial performance of Chinese banks and found that investments in CSR enhanced financial success and environmental goals simultaneously. Sankaran and Rajput (2019) explored the effect of banks through green banking initiatives in India and revealed that public sector banks were performing better in GBP. Rehman et al. (2021) examined the effect of GBP in Pakistan on environmental performance and found that GBP significantly supported environmental policies, daily operations, and green project financing. So, the research indicated that policy and operational practices were promoting environmental efficiency and sustainable banking.

Zhou et al. (2021) investigated the moderating effect of green credit in the association between CSR and BES in Chinese listed banks from 2008-2018 and found that CSR negatively and positively impacted BES in the short and long terms, respectively. Further, green credit also mediated this relationship. Guang-Wen and Siddik (2022) investigated the effects of CSR and green financing on BEP in Bangladesh by using 388 respondents' data and found that CSR positively influenced environmental performance. Additionally, green financing also impacted BEP. Chen et al. (2022) analyzed the impact of GBP on BEP in Bangladesh using data from 322 banking employees and found that employee-related GBP significantly enhanced green financing. However, customer-related GBP could not affect green financing. Additionally, green projects improved environmental performance.

Zhang et al. (2022) examined the impact of GBP on BEP in Bangladesh by using data from 352 bankers and found that GBP enhanced environmental performance. Green financing also mediated this relationship and helped reduce carbon footprints. Hasan et al. (2022) explored the impact of BEP on financial performance in 56 GCC banks from 2010 to 2019 and found that banks' environmental performance negatively affected accounting performance. Gunawan et al. (2022) examined the sustainability and GBP in Indonesian banks and found that economic disclosures were more prominent than environmental disclosures. Hussain et al. (2023) explored and found a positive association between green finance and BEP. Moreover, green finance also provides financial resources for sustainable technologies and practices. Thus, financial innovation fostered sustainable growth by reducing environmental problems.

Chen et al. (2023) examined banking CSR in China and found that bank deregulation significantly improved environmental performance by reducing emission intensity. Islam et al. (2023b) explored the effects of Stakeholders on BEP and CSR through the mediating role of BGP in 30 banks in Bangladesh and found that this pressure significantly enhanced BEP and GBP also mediated this relationship. Taneja and Özen (2023) investigated the influence of green financing on BEF in India and found that environmental strategies and policies improved BEP. Ji et al. (2023) examined 20 banks in China from 2016 to 2020 and found that commercial banks were the most efficient than government banks in performing CSR and BEP. Uddin et al. (2023) investigated the impact of green training on bank employees in Bangladesh by using data from 258 bank employees and found that this training positively influenced employee behaviors, which enhanced organizational environmental sustainability.

Jain and Sharma (2023) assessed the impact of GBP on BES and BEP in Indian banks and found that BEP enhanced BES. GBP also improved operational efficiency and enhanced green project financing, which enhanced BEP and BES consequently. Aslam and Jawaid (2023b) scrutinized the effect of GBP on green satisfaction, perceived quality, trust, and environmental friendliness in Pakistani banking customers and found that GBP positively affected all of these parameters, which helped to increase the customer base for such banks in Pakistan. Aslam and Jawaid (2023a) examined the impact of GBP on banking performance in Pakistan by collecting data from 360 banking personnel and found that GBP positively affected BEP and BES. Bansal et al. (2023) explored the impact of GBP on the BEP in India by using data from 290 bank employees and found that GBP improved BEP and green finance also partially mediated this relationship.

Abuatwan (2023) investigated the influence of green finance on BEP in Palestine by using data from 104 credit managers and found that green financing improved GBP. Moreover, gender diversity positively moderated the nexus between green finance and BEP. Islam et al. (2023a) evaluated the effect of banking green accounting in Bangladesh and found that green accounting and environmental knowledge raised banking green accounting. Additionally, the authors found that it improved the financial performance of banks. Meng and Imran (2024) investigated the effect of CSR on organizational performance in the Malaysian banking sector by the mediating effect of green innovation by using a sample of 550 bank employees and found that CSR positively impacted organizational performance. However, green innovation could not mediate this relationship.

Hermawan and Khoirunisa (2024) examined the effect of GBP on green finance in ASEAN economies and found that GBP improved green financing, which helped improve environmentally friendly activities. Mishra and Sant (2024) investigated the adoption of CSR indicators in the Indian banking sector and found that private banks worked better than government banks in this regard. Moreover, the adoption of international standards was low in Indian banks. Bhuiyan et al. (2024) explored the influence of fintech on BEP in 258 private banks and fintech significantly enhanced employee efficiency and green financing in technologies, which helped improve environmental performance. Chen et al. (2024) examined the role of the banking industry in Taiwan in promoting sustainable growth from 2016-2021 and found that financial holding banks performed better in operational, market, and sustainable efficiencies.

Majeed and Rasheed (2024) investigated Pakistani banks by collecting data from 305 banks and revealed that performance expectancy and social influence enhanced GBP in banks located in Lahore. Moreover, GBP improved BEP and BES. However, the collectivist culture could not moderate this relationship. Newton et al. (2024) investigated the relationship between GBP and the performance of banks in India by collecting data from 393 bank employees in southern India and found that GBP positively influenced BEP. Furthermore, top management commitment also moderated this relationship. Siddik et al. (2024) examined the effect of GBP on BEP in Bangladesh and found that GBP directly impacted green finance and CSR practices. Additionally, green finance also influenced the CSR practices and CSR positively affected the BEP. Green financing and CSR actively mediated the relationship between GBP and BEP.

Mishra and Rath (2024) explored environmental performance through green training and reward systems, which helped improve BEP. Gulzar et al. (2024) examined the impact of GBP on the BEP in India by using data from 500 bank employees and found that GBP improved BEP by focusing on operational procedures. Kumari et al. (2024) reviewed the nexus between GBP, employee green behavior, and BEP and found that employee green behavior mediated the relationship between GBP and BEP, which improved the competitiveness of banks through their environmental performance. The role of employees in GBP was found crucial in transforming banking processes towards sustainable practices and achieving environmental goals.

The reviewed literature highlighted the important role of GBP on BEP considering different mediating and moderating factors. However, this relationship is ignored in Saudi banking literature, which the present study is going to fill.

3. Methods

The study collected the primary data through a questionnaire from employees from the banking sector in Saudi Arabia. The questionnaire consisted of 14 questions related to 3 constructs, i.e., GBP, BEP, and BES. The GBP consisted of banking eco-friendly practices including 5 items related to employee training related to environmentally friendly practices, the usage of energy-efficient equipment, paper-less work, online services, and financing for green projects. The BEP consisted of 5 items related to the usage of eco-friendly equipment, the application of eco-friendly practices, decreasing energy usage, the expected mitigation of emissions from banking services, and banking compliance with environmental standards. BES consisted of 4 items related to reducing cost, and increasing banking customers, profit, and market share. The questionnaire was distributed in Arabic language for the convenience of respondents and translated afterward for data analysis purposes. All items of the questionnaire were asked by a Likert scale from 1 to 5 to conceive the perception about the asked questions. 356 filled questionnaires with valid responses were received. The responses are recorded in an Excel file and then STATA 14.2 is used for data analyses. The items are loaded in their relevant constructs GBP, BEP, and BES. Then, the validity of constructs is measured by CR, AVE, and Cronbach α tests. The minimum values for the reliability of the constructs are 0.7 for CR and Cronbach α , and 0.5 for AVE. After validating our constructs, 2 models are hypothesized, which are estimated using Structural Equation Modelling (SEM). The first model assumes a direct effect of GBP on BEP (H1: The GBP improves the BEP) in the following way:

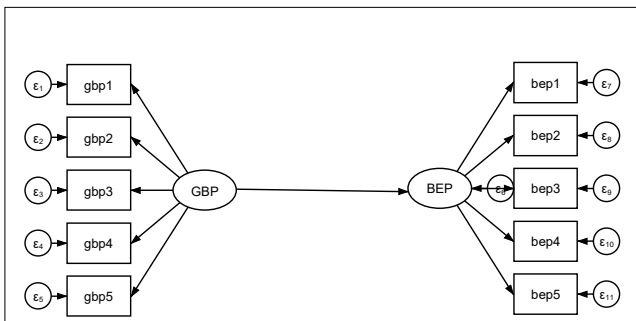

Fig. 1. Model 1 showing the direct effect of GBP on BEP

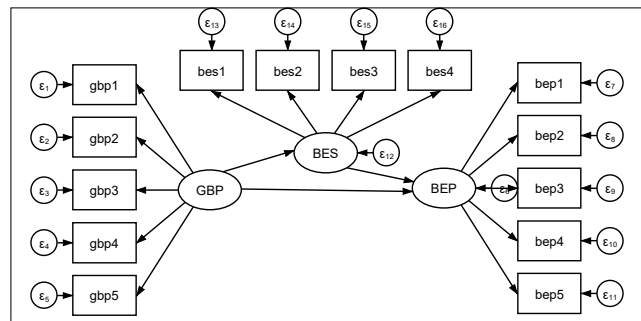

Fig. 2. Model 2 showing the moderating effect of BES on GBP and BEP nexus

After regressing model 1, model 2 assumes the moderating effect of BES in the nexus between GBP and BEP. Thus, GBP may have a direct effect on BEP. Moreover, GBP also determines BEP by affecting BES. The graphical presentation of model 2 is as follows:

Model 2 shows the following hypotheses:

- H₁:** *The GBP improves the BEP.*
- H₂:** *The GBP enhances the BES.*
- H₃:** *BES mediates the nexus between the GBP and the BEP.*

After regressing the models 1 & 2 through SEM, the reliability of results is tested by applying (χ^2/df), CFI, TLI, RMSEA, and SRMS tests with critical bounds 0-3, 0.95-0.97, 0.95-0.97, 0.05-0.08, and 0.05-0.1, respectively, as suggested by Schermelleh-Engel et al. (2003).

4. Data Analysis

At first, the reliability of constructs is tested and reported in Table 1. CR values are 0.763, 0.826, and 0.794 for GBP, BEP, and BES constructs, respectively. Thus, the CR test validates those 5 loaded items with GBP, 5 loaded items with BEP, and 4 loaded items with BES are consistent with the respective constructs. The Cronbach α test validates the findings of the CR test with values 0.801, 0.864, and 0.924 for GBP, BEP, and BES constructs. Thus, all fitted items are associated and consistent with the respective constructs. In addition, AVE values are 0.634, 0.767, and 0.695 for GBP, BEP, and BES constructs, respectively. Thus, the estimated values are more than 0.5 and validate the consistency of items with their respective constructs. Further, 63.4%, 76.7%, and 69.5% variations in GBP, BEP, and BES are due to respective associated items.

Table 1
Reliability Tests

Variables	CR	Cronbach α	AVE
GBP	0.763	0.801	0.634
BEP	0.826	0.864	0.767
BES	0.794	0.924	0.695

Table 2 shows the results from SEM for model 1 and their diagnostic tests. The results of diagnostic tests confirm that model 1 is well-fitted as per the suggested bound critical value of Schermelleh-Engel et al. (2003). Moreover, the estimated positive effect of GBP on BEP validates the H1. Thus, banking green performance helped enhance environmental performance in the banking sector in Saudi Arabia. GBP is measured by several eco-friendly initiatives and policies of banking sectors including training employees in sustainable methods, adopting energy-efficient technologies, transitioning to paperless operations, promoting online services, and financing environmentally beneficial projects. So, the Saudi banks have sufficiently invested in educating their staff about environmental sustainability, which helped the employees to follow and implement green practices in their daily tasks. Thus, the appliance of environmental sustainability practices has been raised in the banking sector. Moreover, the banking sector has transformed its activities with lesser of paper and shifted towards digital practices, which helped in reducing the use of paper and saving the ecological resources associated with paper production and printing. In addition, online banking services have reduced the visits of customers, which has saved fuel consumption associated with their traveling to visit and also reduced paper usage. Moreover, the banks have adopted energy-efficient equipment and devices for their banking operations, which have helped in the reduction of energy usage and associated Greenhouse Gas (GHG) emissions. Lastly, the Saudi banks are encouraging and financing the green projects in the whole economy, which helped in the reduction of GHG emissions.

Table 2

Model 1 estimates

Effect	Parameter	S.E.	z-value	Probability
BEP←GBP	0.074	0.028	2.643	0.008
Diagnostic tests				
χ^2/df	1.974			
CFI	0.963			
TLI	0.951			
RMSEA	0.069			
SRMR	0.085			

Table 3 demonstrates the results of model 2 from SEM and their diagnostic tests. The results of diagnostic tests confirm that model 2 is well-fitted. Moreover, the estimated positive effect of GBP on BEP validates the H2 and the estimated positive effect of GBP on BES validates the H3. Thus, banking green performance directly helped enhance environmental performance and economic sustainability in the Saudi banking sector. In addition, the estimated positive effect of BES on BEP validates the H4. Thus, BES positively mediates the nexus between the GBP and the BEP.

Table 3

Model 2 estimates

Effect	Parameter	S.E.	z-value	Probability
BEP←GBP	0.064	0.026	2.462	0.014
BES←GBP	0.040	0.011	3.636	0.000
BEP←BES	0.231	0.055	4.196	0.000
Diagnostic tests				
χ^2/df	2.352			
CFI	0.959			
TLI	0.968			
RMSEA	0.072			
SRMR	0.069			

In testing the H3, GBP improves BES. Thus, GBP helps in reducing costs by shifting to paperless processes, which leads to lower operational expenses by saving paper costs. Moreover, GBP promotes energy-efficient technologies, which helps to reduce energy bills. Thus, GBP reduces the overall cost of banking operations and helps to increase banking profits. In addition, GBP helped to increase the customer base by marketing their eco-friendly banking operations and the funded eco-friendly projects, which won the confidence of the community and attracted environmentally conscious customers. Thus, GBP increases the banking business by increasing the customer base and achieving customer loyalty. GBP helps in reducing operational costs, increasing revenue by increasing the customer base, and increasing new revenues from green financing. These achievements all together help to boost banking profit and increase the economic sustainability of the banks. Lastly, GBP helps the banks with environmentally friendly practices to differentiate themselves from competitor banks and increase market share as well. Thus, GBP helps in achieving greater economic sustainability.

In testing H4, BES has mediated the nexus between GBP and BEP. BES provides more financial stability to the banks to adopt and perform eco-friendly policies including training employees in sustainable methods, adopting energy-efficient technologies, transitioning to paperless operations, promoting online services, and financing environmentally beneficial projects. Consequently, banks would be able to utilize eco-friendly equipment and other eco-friendly practices, which would reduce energy consumption and GHG emissions to perform the bank in an environmentally sustainable way.

5. Conclusion

GBP would help to achieve BEP. Thus, the present research collected the primary data from 356 employees of the banking sector in Saudi Arabia. A well-structured questionnaire was designed for this purpose to collect data for 5 items on GBP, 5 items on BEP, and 4 items on BES. Using SEM, the mediating role of BES on the relationship between GBP and BEP was tested. The results corroborate that GBP enhances both BEP and BES, and BES improves BEP. Thus, BES has significantly mediated the relationship between GBP and BEP. BES is measured by reducing costs in banking operations, and increasing banking customers, profit, and market share. Thus, BES provides funds to apply eco-friendly practices by purchasing eco-friendly equipment to reduce energy usage in banking operations and GHG emissions. Further, BES enables the banks to comply with environmental standards by providing training to employees to adopt sustainable practices. Moreover, BES provides funds to use eco-friendly equipment to reduce energy consumption and GHG emissions. Thus, GBP through eco-friendly initiatives and policies, transitioning to paperless operations, promoting online services, and financing environmentally beneficial projects helped to achieve BEP targets and achieve environmental sustainability in the banking sector of Saudi Arabia.

Based on the results, the research recommends the banking sector accelerate environmental practices. Particularly, banks should invest more in employee training in compliance with environmental standards and also should adopt eco-friendly equipment and technologies for paperless banking operations, and reduce energy consumption in banking operations to reduce GHG emissions from banking sector operations. Moreover, banks should do marketing of their GBP to increase their environmentally conscious customer base, which will also help the banks to increase their market share compared to the banks not operating sustainable practices. Moreover, banks should increase online banking operations, which will reduce the energy consumption from banking operations and also from the transportation of clients for banking services. Thus, all of these practices will help in the reduction of GHG emissions from banking operations and also from the whole economy.

Acknowledgement

The authors extend their appreciation to Prince Sattam bin Abdulaziz University for funding this research work through the project number (PSAU/2024/02/28917).

References

- Abuatwan, N. (2023). The Impact of Green Finance on the Sustainability Performance of the Banking Sector in Palestine: The Moderating Role of Female Presence. *Economies*, 11(10), 247. <https://doi.org/10.3390/economies11100247>
- Aslam, W., & Jawaid, S. T. (2023a). Green banking adoption practices: improving environmental, financial, and operational performance. *International Journal of Ethics and Systems*, 39(4), 820–840. <https://doi.org/10.1108/ijoes-06-2022-0125>
- Aslam, W., & Jawaid, S. T. (2023b). Let's go green: achieving consumer-related performance outcomes in banks. *International Journal of Ethics and Systems*. <https://doi.org/10.1108/ijoes-01-2023-0019>
- Bansal, N., Taneja, S., & Ozen, E. (2023). Green Financing as a Bridge Between Green Banking Strategies and Environmental Performance in Punjab, India. *International Journal of Sustainable Development and Planning*, 18(10), 3155–3167. <https://doi.org/10.18280/ijstdp.181017>
- Bhuiyan, M. A., Rahman, M. K., Patwary, A. K., Akter, R., Zhang, Q., & Feng, X. (2024). Fintech Adoption and Environmental Performance in Banks: Exploring Employee Efficiency and Green Initiatives. *IEEE Transactions on Engineering Management*, 1–17. <https://doi.org/10.1109/tem.2024.3415774>
- Bose, S., Khan, H. Z., & Monem, R. M. (2020). Does green banking performance pay off? Evidence from a unique regulatory setting in Bangladesh. *Corporate Governance*, 29(2), 162–187. <https://doi.org/10.1111/corg.12349>
- Chen, J., Siddik, A. B., Zheng, G. W., Masukujjaman, M., & Bekhzod, S. (2022). The Effect of Green Banking Practices on Banks' Environmental Performance and Green Financing: An Empirical Study. *Energies*, 15(4), 1292. <https://doi.org/10.3390/en15041292>
- Chen, S., Chen, T., Lou, P., Song, H., & Wu, C. (2023). Bank deregulation and corporate environmental performance. *World Development*, 161, 106106. <https://doi.org/10.1016/j.worlddev.2022.106106>
- Chen, Y., Lin, T., Chiu, Y., & Yang, C. (2024). An exploration of operational efficiency, market efficiency, and sustainable development in the banking industry. *Corporate Social-responsibility and Environmental Management*. <https://doi.org/10.1002/csr.2823>
- Chowdhury, T., Datta, R., & Mohajan, H. (2013). Green finance is essential for economic development and sustainability. *International Journal of Research in Commerce, Economics and Management*, 2013, 3, 104–108
- Dincer, C., & Dincer, B. (2006). Has Environmental Investment a Marketing Effect in Turkish Banking Industry? *Social Responsibility Journal*, 2(1), 88–95. <https://doi.org/10.1108/eb045826>
- Guang-Wen, Z., & Siddik, A. B. (2022). Do Corporate Social Responsibility Practices and Green Finance Dimensions Determine Environmental Performance? An Empirical Study on Bangladeshi Banking Institutions. *Frontiers in Environmental Science*, 10. <https://doi.org/10.3389/fenvs.2022.890096>

- Gulzar, R., Bhat, A. A., Mir, A. A., Athari, S. A., & Al-Adwan, A. S. (2024). Green banking practices and environmental performance: navigating sustainability in banks. *Environmental Science and Pollution Research International*. <https://doi.org/10.1007/s11356-024-32418-7>
- Gunawan, J., Permatasari, P., & Sharma, U. (2022). Exploring sustainability and green banking disclosures: a study of banking sector. *Environment, Development and Sustainability*, 24(9), 11153–11194. <https://doi.org/10.1007/s10668-021-01901-3>
- Hasan, R., Miah, M. D., & Hassan, M. K. (2022). The nexus between environmental and financial performance: Evidence from Gulf Cooperative Council banks. *Business Strategy and the Environment*, 31(7), 2882–2907. <https://doi.org/10.1002/bse.3053>
- Hermawan, S., & Khoirunisa, Z. A. (2024). The Emergence of Green Banking: A Sustainable Financing Strategy for Protecting Against Deforestation in ASEAN. *the α Journal of Environment & Development/Journal of Environment & Development*, 33(1), 96–124. <https://doi.org/10.1177/10704965231211591>
- Hussain, S., Rasheed, A., & Rehman, S. U. (2023). Driving sustainable growth: exploring the link between financial innovation, green finance and sustainability performance: banking evidence. *Kybernetes*. <https://doi.org/10.1108/k-05-2023-0918>
- Islam, M. S., Rubel, M. R. B., & Hasan, M. M. (2023). Environmental and Social Performance of the Banking Industry in Bangladesh: Effect of Stakeholders' Pressure and Green Practice Adoption. *Sustainability*, 15(11), 8665. <https://doi.org/10.3390/su15118665>
- Islam, S., Islam, M. S., Hassan, M. R., Arafat, A. B. M. Y., Ahmed, S., Hoque, S., & Sultana, T. (2023). Evaluating the success of green accounting practices in the banking sector of Bangladesh. *International Journal of Applied Economics, Finance and Accounting*, 17(2), 497–508. <https://doi.org/10.33094/ijaefa.v17i2.1215>
- Jain, P., & Sharma, B. K. (2023). Impact of Green Banking Practices on Sustainable Environmental Performance and Profitability of Private Sector Banks. *International Journal of Social Ecology and Sustainable Development*, 14(1), 1–19. <https://doi.org/10.4018/ijesed.330135>
- Ji, L., Sun, Y., Liu, J., & Chiu, Y. H. (2023). Environmental, social, and governance (ESG) and market efficiency of China's commercial banks under market competition. *Environmental Science and Pollution Research International*, 30(9), 24533–24552. <https://doi.org/10.1007/s11356-022-23742-x>
- Kumari, J., Gupta, C., Jindal, P., Mishra, A., & Sood, K. (2024). Enhancing Banking Sustainability Through Employee Green Behaviour and Green Banking Initiative: A Synergistic Approach For a Greener Future. In *Contemporary studies in economic and financial analysis* (pp. 133–145). <https://doi.org/10.1108/s1569-37592024000113a008>
- Lekakos, G., Vlachos, P., & Koritos, C. (2014). Green is good but is usability better? Consumer reactions to environmental initiatives in e-banking services. *Ethics and Information Technology*, 16(2), 103–117. <https://doi.org/10.1007/s10676-014-9337-6>
- Liu, N., Liu, C., Xia, Y., Ren, Y., & Liang, J. (2020). Examining the Coordination Between Green Finance and Green Economy Aiming for Sustainable Development: A Case Study of China. *Sustainability*, 12(9), 3717. <https://doi.org/10.3390/su12093717>
- Majeed, A., & Rasheed, A. (2024). Green banking adoption in Pakistan: the UTAUT model augmented with green consumption values, environmental concerns, and collectivism culture. *Journal of Environmental Planning and Management*, 1–34. <https://doi.org/10.1080/09640568.2024.2327841>
- Malsha, K. P. P. H. G. N., Arulrajah, A. A., & Senthilnathan, S. (2020). Mediating role of employee green behaviour towards sustainability performance of banks. *Journal of Governance and Regulation*, 9(2), 92–102. <https://doi.org/10.22495/jgrv9i2art7>
- Meng, X., & Imran, M. (2024). The impact of corporate social responsibility on organizational performance with the mediating role of employee engagement and green innovation: evidence from the Malaysian banking sector. *Ekonomika Istraživanja/Ekonomika Istraživanja*, 37(1). <https://doi.org/10.1080/1331677x.2023.2264945>
- Mishra, P., & Sant, T. G. (2024). Examine the level of environmental, social and governance disclosure in sustainability report – a study of the Indian banking sector. *International Journal of Innovation Science*. <https://doi.org/10.1108/ijis-08-2022-0136>
- Mishra, S., & Rath, N. (2024). Impact of Green Human Resource Management Practices on Environmental Performance of Indian Banking Sector: An Empirical Study. *International Journal of Sustainable Development and Planning*, 19(4), 1457–1469. <https://doi.org/10.18280/ijstdp.190423>
- Nawaz, M. A., Seshadri, U., Kumar, P., Aqdas, R., Patwary, A. K., & Riaz, M. (2020). Nexus between green finance and climate change mitigation in N-11 and BRICS countries: empirical estimation through difference in differences (DID) approach. *Environmental Science and Pollution Research*, 28(6), 6504–6519. <https://doi.org/10.1007/s11356-020-10920-y>
- Newton, S., Susainathan, S., George, H. J., Quttainah, M., & Parayitam, S. (2024). Top Management Commitment as a Moderator in the Relationship Between Green Banking Adoption Practices and Performance: Evidence from India. *Indian Journal of Corporate Governance*, 17(1), 33–62. <https://doi.org/10.1177/09746862241236553>
- Rai, R., Kharel, S., Devkota, N., & Paudel, U. R. (2019). Customers perception on green banking practices: A desk. *The Journal of Economic Concerns*, 10(1), 82-95.
- Rehman, A., Ullah, I., Afridi, F. E. A., Ullah, Z., Zeeshan, M., Hussain, A., & Rahman, H. U. (2021). Adoption of green banking practices and environmental performance in Pakistan: a demonstration of structural equation modelling. *Environment, Development and Sustainability*, 23(9), 13200–13220. <https://doi.org/10.1007/s10668-020-01206-x>

- Risal, N., & Joshi, S. K. (2018). Measuring Green Banking Practices on Bank's Environmental Performance: Empirical Evidence from Kathmandu Valley. *Journal of Business and Social Science*, 2(1), 44–56. <https://doi.org/10.3126/jbss.v2i1.22827>
- Sankaran, S., & Rajput, N. (2019). An Empirical Study Among Customers and Employees on Green Banking Practices in India. *Journal of Advanced Research in Dynamic and Control Systems*, 11, 1792–1807. <https://www.jardcs.org/abstract.php?id=1664>
- Schermelleh-Engel, K., Moosbrugger, H., & Muller, H. (2003). Evaluating the fit of structural equation models: Tests of significance and descriptive goodness-of-fit measures. *Methods of Psychological Research Online*, 8(2), 23–74.
- Shaumya, K., & Arulrajah, A. (2017). The impact of green banking practices on bank's environmental performance: Evidence from Sri Lanka. *Journal of Finance and Bank Management*, 5(1), 77-90.
- Siddik, A. B., Yong, L., & Sharif, A. (2024). Do sustainable banking practices enhance the sustainability performance of banking institutions? Direct and indirect effects. *International Journal of Bank Marketing*. <https://doi.org/10.1108/ijbm-02-2023-0109>
- Taneja, S., & Özen, E. (2023). To analyse the relationship between bank's green financing and environmental performance. *International Journal of Electronic Finance*, 12(2), 163. <https://doi.org/10.1504/ijef.2023.129919>
- Tara, K., & Singh, S. (2014). Green Banking: An Approach Towards Environmental Management. *Prabandhan : Indian Journal of Management*, 7(11), 7. <https://doi.org/10.17010/pijom/2014/v7i11/59258>
- Uddin, M. S., Rahaman, M. A., Latif, W. B., Dona, P. D., & Kundu, D. (2023). Impact of green HRM practices on bank employee service behaviors. *Banks and Bank Systems*, 18(4), 85–93. [https://doi.org/10.21511/bbs.18\(4\).2023.08](https://doi.org/10.21511/bbs.18(4).2023.08)
- Weber, O. (2017). Corporate sustainability and financial performance of Chinese banks. *Sustainability Accounting, Management and Policy Journal*, 8(3), 358–385. <https://doi.org/10.1108/sampj-09-2016-0066>
- Zhang, X., Wang, Z., Zhong, X., Yang, S., & Siddik, A. B. (2022). Do Green Banking Activities Improve the Banks' Environmental Performance? The Mediating Effect of Green Financing. *Sustainability*, 14(2), 989. <https://doi.org/10.3390/su14020989>
- Zhou, G., Sun, Y., Luo, S., & Liao, J. (2021). Corporate social responsibility and bank financial performance in China: The moderating role of green credit. *Energy Economics*, 97, 105190. <https://doi.org/10.1016/j.eneco.2021.105190>



© 2025 by the authors; licensee Growing Science, Canada. This is an open access article distributed under the terms and conditions of the Creative Commons Attribution (CC-BY) license (<http://creativecommons.org/licenses/by/4.0/>).