

# Uncertain Supply Chain Management

homepage: [www.GrowingScience.com/uscm](http://www.GrowingScience.com/uscm)

## Exploring the adoption of photovoltaic cleaning robots: An institutional management approach

Rubporn Promvongsanon<sup>a</sup>, Sudaporn Sawmong<sup>a\*</sup> and Bilal Khalid<sup>a</sup>

<sup>a</sup>*KMITL Business School, King Mongkut's Institute of Technology Ladkrabang, Bangkok 10520, Thailand*

### ABSTRACT

#### Article history:

Received April 23, 2024  
Received in revised format April 27, 2024  
Accepted April 29 2024  
Available online  
May 1 2024

#### Keywords:

*Photovoltaic  
Solar energy  
Cleaning robots  
Technology adoption  
Management strategies  
Institutional perspective*

There is increased adoption of renewable energy, particularly photovoltaic (PV), as a major source of clean and environmentally friendly energy. With the wide application of PV technologies, commonly called solar panels, their appropriate maintenance and cleaning are vital for optimum PV energy generation. The research focuses on exploring the various factors attributed to influence the want, intention and need to use PV panel cleaning robots in Thailand from an institutional management perspective. The study adopted the extended C-TAM-TPB by adding three more variables - Trust in technology, awareness of renewable energy, and environmental concern. A quantitative approach was used, where primary data was collected from PV institutional users. A population sample of 411 respondents was used. The confirmatory factor analysis (CFA) came in handy in evaluating the performance model, with the study's hypotheses being evaluated by the structural equation modeling (SEM). Results indicated that most of the subjective behaviors, perceived behavioral controls, and trust in technology played a key role in determining the intention and need to use solar panel cleaning robots. Perceived usefulness was found to have significant influence towards PV panel adoption. The influence of attitude was mediated by several factors – environmental concern, renewable energy awareness, trust in technology. The study recommended that the institutional users of solar panels should consider investing in knowledge regarding perceived behavioral control, developing confidence in the use of renewable and sustainable energy, and developing trust of the renewable and sustainable energy technologies. This could be achieved through programs such as public awareness, sharing accurate information regarding solar panel cleaning robots, and providing support and after sales support. Educational initiatives to change users' attitudes toward renewable energy technologies were recommended.

© 2024 by the authors; licensee Growing Science, Canada.

## 1. Introduction

Renewable energy is the energy source for the future, especially considering the irreversible climatic changes, global warming challenges, diminishing resources, and increasing environmental pollution from other non-renewable and fossil fuel sources (Ahmadi et al., 2018; Nijisse et al., 2023). Solar energy generated through photovoltaic (PV) cells is considered among the most suitable sources of renewable energy (Glunz et al., 2012). The solar radiation rays are captured by PV technologies and systems, and they are converted to usable energy. The cells concentrate the sun's rays into a central point, which is then converted into solar energy. This energy could then be applied in various institutional and industrial uses, including lighting and powering machines (Bundschuh et al., 2021). From a chemical reaction perspective, solar energy is developed through the reaction of hydrogen and helium (Namazov et al., 2023). Solar energy is considered a strong source because it could be harnessed to be applied in various ways. These ways include in the form of electricity, for heating, and for lighting. Majorly, the PV systems connect solar energy to electricity. These PV solar systems are placed in places they can receive maximum sunlight, such as rooftops. To maintain effective solar energy generation, regular cleaning of the solar panel surfaces is needed. These surfaces of the solar panels could settle dust and other particles that could prevent sun rays from penetrating well. The

\* Corresponding author

E-mail address [Sudaporn.sa@kmitl.ac.th](mailto:Sudaporn.sa@kmitl.ac.th) (S. Sawmong)

ISSN 2291-6830 (Online) - ISSN 2291-6822 (Print)

© 2024 by the authors; licensee Growing Science, Canada.

doi: 10.5267/j.uscm.2024.4.023

dust could also damage the panels, reducing their lifespan (Rashid et al., 2023). After years of use, this dirt can damage your panels beyond repair or even cause them to fail in other ways. In Thailand, there is a problem with dust, and the probability of solar panels reducing their efficiency by more than 35% is high (Namazov et al., 2023). Various methods could be applied to clean solar panels depending on the environmental factors. Some methods include manual cleaning by humans and automatic cleaning by robots. PV panels are sometimes installed at high levels, making cleaning them manually daunting (Patil et al., 2017), making the application of robotic cleaning methods inevitable. The cleaning robots applied to clean PV panels are technologies used for efficient and effective cleaning of solar panels. They are considered so because they eliminate the extensive human labor and human error (Olayiwola et al., 2024). Considering the increased adoption and use of solar energy generated using PV systems, the exploration of robotic cleaning technologies is critical too. Therefore, this study was conducted to investigate what determines this adoption and use form the industrial and institutions in Thailand. This was met by answering these research objectives:

1. To study the intention of institutional users in Thailand to use solar panel cleaning robots,
2. To analyze factors that directly and indirectly intend to use solar panel cleaning robots by institutions in Thailand,
3. To develop the intention to use solar panel cleaning robots in Thailand - extended C-TAM-TPB model.

The study's findings will benefit institutional users such as organizations and businesses in Thailand that rely on solar energy for their operations; they will learn how they can enhance their overall operational efficiency. This includes the economic benefits of reduced maintenance costs and the potential for increased energy generation due to cleaner PV panels. In hindsight, PV panel cleaning robots positively impact the national economy by creating jobs, generating revenue, reducing costs, and protecting the environment (Liang et al., 2023; Sun & Böhringer, 2020).

## 2. Literature Review

Renewable energy implies the energy that does not get extinguished on usage and is replenished naturally as it is being used. It includes sunshine, water, and wind energy. In recent times, solar energy is considered a great driver towards global movement towards green energy initiatives (Hosseini & Wahid, 2020). It is significantly addressing global, regional as well as national climate change concerns, through enhancing the aspects of sustainability and reduction of the emissions of greenhouse gases (Jurasz et al., 2020; Straka et al., 2021). It is established that more people are becoming aware and conscious of renewable energy sources and are adopting the use of solar-power panels as the key source of their energy both in households and institutions. Renewable energy sources are considered vital because they encourage energy diversity, lessening reliance on scarce resources and improving energy security (Mofijur et al., 2019). Another characteristic of solar energy is its readiness and availability without limitation, which makes it a unique source of energy (Colak et al., 2020). It is therefore considered to have a great potential to address global energy concerns (Nwaigwe et al., 2019, Obaideen et al., 2021).

### 2.1 Photovoltaic Panels and Cleaning Robots

Professional maintenance is crucial for the efficient and long-lasting use of solar panels. Regular cleaning from dust and other particles that may fall on the surface is essential for optimal solar power absorption. If the dust and particles are not frequently removed, the effectiveness of solar power absorption is significantly reduced (Chen et al., 2019). Robots, such as those used in industrial PV panel power generation systems, can effectively remove dust, particles and other pollutants from the panels' surface using various methods automatically through remote control operations (Kawamoto, 2019). This autonomous operation reduces labor costs and frees up personnel resources for other maintenance tasks. Additionally, robots improve cleaning accuracy compared to human procedures, ensuring complete and efficient dirt and dust removal, ultimately increasing energy production and system efficiency, that ultimately increase the span of the PV systems and the amount of energy generated (Jurasz et al., 2020).

### 2.2 C-TAM-TPB Model & Hypothesis Development

This incorporated two models - Technology Acceptance Model (TAM) and Theory of Planned Behavior (TPB) to form a comprehensive framework and model dubbed C-TAM-TPB model. These individual models have widely been applied and utilized in previous researches like Nguyen et al. (2023) and Xue et al. (2024). Both models contribute varying perspectives. For the TAM model, they informed about the users' attitudes and intentions of technology adoption, the TPB brought in the perspectives of perceived behavior control and subjective norm (Davis, 1989; Gansser & Reich, 2021). The TAM demystifies the psychological behaviors that drive people towards using a particular new technological advancement (Pal et al., 2020).

### 2.3 Subjective Norms Effects on Intention to Use

Subjective behaviors or norms account for the influential perspectives and pressures from people who position themselves close, concerning a particular behavior. These close people could be friends, relatives, coworkers, among others. According to the definition given by Villana-Taranilla et al. (2023) the subjective norm implies the individual's perception of whether important members of their social network support or oppose using the technology. Troise et al. (2021) performed an

examination on the interplay between behavioral intent and subjective norm within the realm of online food delivery services. Their study employed an integrated approach that drew upon the Technology Acceptance Model (TAM) and Theory of Planned Behaviour (TPB). In the study on the incorporation of digital meal delivery services, Darmansyah et al. (2020) established that subjective behaviors positively impacted individual behavioral intentions. This demonstrates that social influence, such as ideas or comments from others, might impact individuals' inclination to utilize a service. This investigation demonstrates that subjective norms, which measure social impact, have a positive correlation with individuals' propensity towards using various technological advancements and services. The influence of social pressure, expectations, and recommendations from important others or society might impact individuals' willingness to adopt and utilize specific technology or engage in certain behaviors. The following hypothesis was therefore developed:

**H<sub>1</sub>:** *Subjective Norm significantly influences the behavioural intention to use PV panel cleaning robots.*

#### 2.4 Perceived Behavioral Control

PBC implies the perceptions of the people in their abilities to determine how they could adopt and utilize a particular technology. It involves the resources and capabilities at the disposal of the concerned individual that could play a role in adopting a particular technological development (Okpala et al., 2022). Through research by Sultan et al. (2020) investigated the perceived behavior control and the intentional behavior gap in the process of organic food consumption. They found that the difference between people's intentions and actual behavior towards eating organic food was less when people had a high conviction in their capacity to control such behavior. These studies draw attention to the recurrent finding that behavioral intention to use favorably correlates with perceived behavioral control. People possess the likelihood to create the intention to participate in certain behaviors when they believe they control their actions or behaviors in a certain situation (Holotová et al., 2020; Teo et al., 2019). This association indicates that increasing people's feelings of control may be useful for encouraging desired behaviors or the adoption of technology in various contexts. The hypothesis that was proposed is as follows:

**H<sub>2</sub>:** *Perceived Behavior Control possesses both the positive and significant impacts on the behavioral intent to use PV panel cleaning robots.*

#### 2.5 Attitudes

The C-TAM-TPB Model uses the term "attitudes" to describe how a person feels about adopting technology in general or whether they feel positively or negatively about it. From the perspective of Gansser and Reich (2021), attitude implies the emotive and cognitive factors related to the individual's perception and cognitive towards a particular technology. A study by Liang and Chi (2021) investigated how attitude is influenced by perceived risk. They demonstrated the significance of user attitude as far as participation in blockchain is concerned. Another study by Kumar and Sreen (2020) how various factors influenced the adoption of WhatsApp usage. A positive attitude was found to be critical in determining the way mobile education was adopted and utilized. Convenience, efficacy, subjective norm, perceived danger, self-efficacy, and past use patterns are a few variables that affect attitude. Practitioners and policymakers may build efficient initiatives and strategies that encourage the uptake and usage of certain goods or products by understanding the interplay between people's attitude and intention. Secondly, the research hypothesis proposed has its basis on the literature arguments:

**H<sub>3</sub>:** *Attitude possesses both positive and significant impacts on the behavioral intent to using PV panel cleaning robots.*

#### 2.6 Trust in Technological Impacts on Intention to Use

Trust implies the belief or reliance that a person has concerning another person. It is a conviction towards a particular subject, particularly in response to the performance of an activity by a person (Gambetta, 1988). From the perspective of technology, McKnight (2005) defined trust in technology as the conceptualized belief of an individual in the hope of effective functionality and reliability of the concerned technology. The different definitions of trust are summarized below. A study by Fitrianie et al. (2021) on the usage of mobile phones indicated that trust is one of the significant factors that lead to the adoption and use of mobile phones cognitive therapy. Another study by Chao (2019) indicated that trust, among other factors, has a significant influence on mobile learning. These hypotheses were therefore developed:

**H<sub>4</sub>:** *Trust in technology has both positive and significant impacts on the behavioral intent to use PV panel cleaning robots.*

**H<sub>9a</sub>:** *Trust in technology significantly mediates the impacts of attitude on behavioral intention to use PV panel cleaning robots.*

#### 2.7 Awareness of Renewable Energy effects on Intention to Use

Awareness generally denotes the state of being aware, alert, and conscious. However, the concept of awareness is properly understood based on the context in which it is applied. From the renewable energy perspective, awareness refers to consumer interpretation, knowledge and view of facts and aspects related to renewable and sustainable energy technologies (Mukhtarov et al., 2023; Wall et al., 2021). A study was carried out by Maciaszczyk et al. (2022) to find out how consumers were aware

of renewable energy. The study indicated that there was a correlation between the renewable energy adoption and the aspects of age of the users and education levels. Another study was carried out by Irfan et al. (2021) to find out how the public was accepting and using renewable energy in Pakistan. The level of awareness by the users was a contributing factor towards the use of renewable energy. As people become aware of renewable energy, they are more inclined towards using renewable systems and technologies. With basis on this, the following hypothesis were developed:

**H<sub>5</sub>:** *Awareness of renewable energy significantly influences people's behavioral intent to use PV panel cleaning robots.*

**H<sub>9b</sub>:** *Awareness of renewable energy significantly mediates the impact of attitude on the behavioral intent to use PV panel cleaning robots.*

### 2.8 Environmental Concerns effects on Intention to use

Wall et al. (2021) postulated that environmental concern indicates people's attitudes and knowledge regarding addressing environmental issues such as climate change and pollution. Ecological concern is also considered to be the level of awareness, sensitivity, and care individuals or societies have towards the state of the environment and the impact of human activities on natural ecosystems (Cruz & Manata, 2020). Nasirov et al. (2018) investigated the renewable energy transition as a market-driven solution to environmental concerns in Chile. They found that there is a need for a combination of clear decision-making, persistent and consistent government policies, and a clear commitment to the set strategies for renewable energy. Chen and Aklikokou (2020) measured energy efficiency performance in China by evaluating the aspects of technology and environmental concerns. The study demonstrated the role of environmental concerns and the contribution towards governance. The above literature led to the development of the following hypothesis:

**H<sub>6</sub>:** *Environmental concern significantly influences the behavioral intention to use PV panel cleaning robots.*

**H<sub>9c</sub>:** *Environmental concern significantly mediates the impacts of attitude on behavioral intent to using PV panel cleaning robots.*

### 2.9 Perceived Usefulness, Perceived Ease of Use and Attitude

Attitude refers to the opinion or feeling that a person usually has regarding something or someone else. It could also be considered as a perspective regarding something or someone.

There is a quite significant number of studies that has been conducted to investigate the relationship among the three variables. One of these studies was conducted by Kaur (2020) whose focus was to find out the factors that determine use of e-government services. There were interesting results that attitude is significantly related to perceived usefulness regarding the use of e-government services. The second study that evaluated the same area was by Huang (2020) whose objective was to determine how attitude is influenced by the aspects of perceived usefulness as well as perceived ease of use in matters of learning techniques. The researchers' result indicated that the two variables were significant influencers of people's attitude towards this technology. It therefore led to the proposition that these two aspects are critical towards technology adoption. The following were proposed:

**H<sub>7</sub>:** *Perceived usefulness significantly influences the attitude towards behavioral intention to use PV panel cleaning robots.*

**H<sub>8</sub>:** *Perceived ease of use significantly influences the behavioral intention to use PV panel cleaning robots.*

## 3. Research Methodology

### 3.1 Research Design

The study incorporates the C-TAM-TPB model as its background theoretical model in informing the research. In addition to the usual variables of the model, three variables were added, which are trust in technology, awareness of renewable energy, and environmental concern. These variables were developed from literature sources such as journal articles and relevant literature. The study uses the cross-sectional survey design in collecting primary data from solar panel institutional consumers in Thailand.

### 3.2 Participants and Procedures

The study population comprised institutions using solar panels as a solar energy source. The data from Thailand PV Status Report 2021 indicated that in 2020, Thailand's cumulative grid-connected PV system capacity increased to 3,933.7 MWp, with total installation amounting to 3,939.8 MWp. The cumulative installed PV systems of licensed and non-registered with exceptional cases during 2020 totaled 910.06 MWp from 1,191 projects (Ministry of Energy, 2021). A representative sample was developed from which the study data was collected. This research adopted the probability sampling method, which involves random selection, providing each member of the population with a known chance of being included in the survey. By adopting the Hair et al. (2019) sample-to-variable ratio, a minimum observation-to-variable ratio of 15:1, the minimum sample size was 390 respondents. A stratified sampling technique was adopted to collect data from four major regions in

Thailand - North Region, North Eastern Region, Central Region, and Southern Region. The distribution of the sample size used is summarized in Table 1.

**Table 1**  
Population and Sample Selection

Region	No. of projects in each region	Sample = Institutional Users
Northern Region	474	159
North Eastern Region	243	82
Central Region	292	98
Southern Region	182	61
<b>Total</b>	<b>1,191</b>	<b>400</b>

### 3.3 Data Collection and Measures

The study incorporated a structured questionnaire in collecting data from the respondents. The structure of the questionnaire was developed with questions designed to answer all the research hypotheses. A pretest was conducted to assess the validity and clarity of the questionnaire's content. The questionnaire was developed using existing scales utilized in prior scholarly works (see Table 2). It was administered using emails, and the respondents were requested to fill out the questionnaire on Google Forms and submit it. The first section considered the demographic data of the respondents. The second section captured the study variables data, where 5-point Likert scale questions were used, where 5=strongly agree and 1=strongly disagree. The latent variable, observed variable, and sources are summarized in Table 2.

**Table 2**  
Study Variables and Sources

Latent Variables	Observed Variables	Symbols
Perceived Usefulness	System Effectiveness	Chen and Aklikokou, (2020); Akther and Nur, (2022);
	Relevance to the Needs	
	Impact on Productivity	
Perceived Ease of Use	Interface Complexity	Keni (2020); Giraldo et al. (2021)
	Learning Curve	
	Assistance & Support	
Perceived Behavioral Control	Self-Efficacy	Banerjee and Ho (2020) Li et al., (2020)
	Perceived Resources & Support	
	Perceived Complexity	
Subjective Norm	Social Influence	Cialdini and Goldstein (2004); Aschwanden, et al. (2021)
	Normative beliefs	
	Reference group influence	
Trust in Technology	Perceived Reliability	Fitriani et al. (2021). Manrai and Gupta, (2020).
	Perceived Privacy & Security	
	Reputation	
Awareness of Renewable Energy	Knowledge about Renewable Energy	Maciaszczyk et al. (2022); Al-Marri Al-Habaibeh and Watkins (2018)
	Awareness of Environmental Benefits	
	Familiarity with Renewable Energy	
Environmental Concerns	Pro-Environmental Attitudes	Nasirov et al. (2018); Shukla and Kumar (2020).
	Sustainable Behavior Engagement	
	Perceived Environmental Impact	
Behavioral intention to use	Intention to Use	Tseng et al. (2022); Shiau and Chau (2016).
	Prediction to Use	
	Planning to Use	
Attitude	Cognitive evaluation	Angelia et al. (2021); Sattari et al. (2017)
	Affective response	

## 4. Results

The demographic analysis evaluated all characteristics of the respondents' companies. The first analysis was the company type. The majority were private companies (43.6%), followed by public companies (31.1%), and lastly, the government (25.3%). The other analysis was the age of the companies. The majority were those in 4-10 years (30.4%), followed by those in 21-30 years (24.6%), and the last were those in 31-40 years (3.4%). The other aspect that was evaluated was the turnover of the respondent companies, where the majority were 50 – 100 million Thai Baht (23.4%), followed by those in 100 – 499 million Thai Baht (22.9%), and the last category was those above 1000 million Thai Baht (15.6%). The previous aspect evaluated was the number of electricity units consumed, where the largest was more than 100,001 Units – 500,000 Units (37.2%), followed by Less than 49,999 – 100,000 Units (23.4%). The last category was 500, 0001 Units – 100,000,000 Units (18.5%).

**Table 3**  
Demographic Characteristics of Respondents

Variables	Measurement	n	%
Company type	Private	179	43.6
	Public	128	31.1
	Government	104	25.3
	Total	411	100
Age	Under 3 years	64	15.6
	4-10 years	125	30.4
	11-20 years	107	26
	21-30 years	101	24.6
	31-40 years	14	3.4
	Total	411	100
Turnover	Under 49 million Thai Baht	91	22.1
	50 – 100 million Thai Baht	96	23.4
	100 – 499 million Thai Baht	94	22.9
	500 – 1000 million Thai Baht	66	16.1
	Above 1000 million Thai Baht	64	15.6
	Total	411	100
Units	Less than 49,999 – 100,000 Units	96	23.4
	More than 100,001 Units – 500,000 Units	153	37.2
	500,0001 Units – 100,000,000 Units	76	18.5
	More than 100,000,000 Units	86	20.9
	Total	411	100

#### 4.1 Model Fitness Evaluation

The results for the CFA indicated that the chi-square statistic for the model was significant ( $\chi^2$  [257] = 690.689,  $p < 0.01$ ), also expressed as  $\chi^2$  /df ratio = 2.688. It satisfied the required threshold of  $< 5.0$  (Schumacker & Lomax, 2004). Evaluating other fitness indices indicated that CFI = 0.946, TLI = 0.931, IFI = 0.946, and NFI = 0.917. These values satisfied the required threshold of  $> 0.90$ . RMSEA = 0.064, which was within the required threshold of  $< 0.08$ , while GFI = 0.895 which was within required threshold of  $> 0.80$ . Since these statistics were satisfactory, it was conclusive that the proposed model fitted well to the data.

**Table 4**  
Model Evaluation Analysis

Fit index	Threshold	Stat value	Conclusion
$\chi^2$ /df ratio	$< 5.0$	2.688	satisfactory
CFI	$> 0.90$	0.946	satisfactory
TLI	$> 0.90$	0.931	satisfactory
IFI	$> 0.90$	0.946	satisfactory
NFI	$> 0.90$	0.917	satisfactory
RMSEA	$> 0.080$	0.064	satisfactory
GFI	$> 0.80$	0.895	satisfactory
<b>Conclusion</b>			<b>Model Fit</b>

For the institutional users' case, the factor loadings, average variance extracted (AVE), and convergent reliability (CR) were evaluated for each latent variable and their observed variables. The threshold for factor loadings is  $> 0.5$ , for AVE is 0.5, while that of CR is 0.7 (Fornell & Larcker (1981), Nunnally and Bernstein, 1994; Segars, 1997). Factor loadings ranged from -0.07 (SYE) to 0.903 (IP) for the observed variable perceived usefulness. The CR was 0.793, and the AVE was 0.678. These statistics satisfied all the required thresholds apart from a slight deviation for SYE and RN. Factor loadings ranged from 0.039 (AR) to 0.928 (CE) for the observed variable attitude. The CR was 0.851, while the AVE was 0.631. These statistics satisfied all the required thresholds apart from the AR case. For the observed variable, perceived behavior control factor loadings ranged from 0.871 (PR) to 0.885 (SE). The CR was 0.911, conversely, the AVE was 0.733. These statistics satisfied all the required thresholds. For the observed variable, subjective norm factor loadings ranged from 0.741 (NB) to 0.858 (RG). The CR was 0.825, and the AVE was 0.616. These statistics satisfied all the required thresholds. For the observed variable, perceived ease of use factor loadings ranged from 0.864 (IC) to 0.900 (LC). The CR was 0.918, while the AVE was 0.788. These statistics satisfied all the required thresholds. For the observed variable, trust in technology factor loadings ranged from 0.707 (PP) to 0.843 (RT). The CR was 0.825, while the AVE was 0.612. These statistics partially satisfied all the required thresholds. For the observed variable awareness of renewable energy, the factor loadings ranged from 0.764 (FM) to 0.856 (EB). The CR was 0.853, in accordance, the AVE was 0.660. These statistics satisfied all the required thresholds. The factor loadings ranged from 0.807 (SB) to 0.924 (PEA) for the observed variable environmental concern. The CR was 0.897, while the AVE was 0.744. These statistics satisfied all the required thresholds. The factor loadings ranged from 0.758 (PU) to 0.892 (PLU) for the observed variable behavioral intention to use. The CR was 0.876, and the AVE was 0.702. These statistics satisfied all the required thresholds.

**Table 5**  
Model Evaluation Results

Relationships	Factor Loadings			T-stat	CR	AVE
	Estimate	S.E.	Beta			
IP ← PU	1.00		0.903			
RN ← PU	-0.09	0.04	-0.112	2.21	0.793	0.678
SYE ← PU	-0.05	0.04	-0.07	-1.40		
CE ← AT	1.00		0.928		0.851	0.631
AR ← AT	0.04	0.14	0.039	0.32		
SE ← PBC	1.00		0.885			
PR ← PBC	1.00	0.04	0.871	22.507**	0.911	0.773
PC ← PBC	1.12	0.05	0.881	21.074**		
SI ← SN	1.00		0.751			
NB ← SN	0.93	0.05	0.741	17.134**	0.828	0.616
RG ← SN	1.26	0.08	0.858	15.012**		
AS ← PEU	1.00		0.898			
LC ← PEU	1.03	0.04	0.900	27.725**	0.918	0.788
IC ← PEU	0.98	0.04	0.864	25.291**		
RT ← TT	1.00		0.843			
PP ← TT	0.93	0.06	0.707	16.978**	0.825	0.612
PRE ← TT	0.90	0.04	0.791	20.118**		
FM ← ARE	1.00		0.764			
EB ← ARE	1.02	0.06	0.856	16.615**	0.853	0.660
KN ← ARE	0.96	0.06	0.814	16.087**		
PEI ← EC	1.00		0.852			
SB ← EC	0.98	0.05	0.807	19.399**	0.897	0.744
PEA ← EC	1.16	0.06	0.924	21.215**		
IU ← BIU	1.00		0.858			
PU ← BIU	0.98	0.05	0.758	18.71**	0.876	0.702
PLU ← BIU	1.08	0.04	0.892	24.784**		

4.2 Hypothesis Evaluation

The SEM for empirical evaluation of the variables for the case of institutional users. For model fitness, the SEM analysis model was also assessed for suitability and fitness. The model fitness indicators were recorded as follows in Table 6:

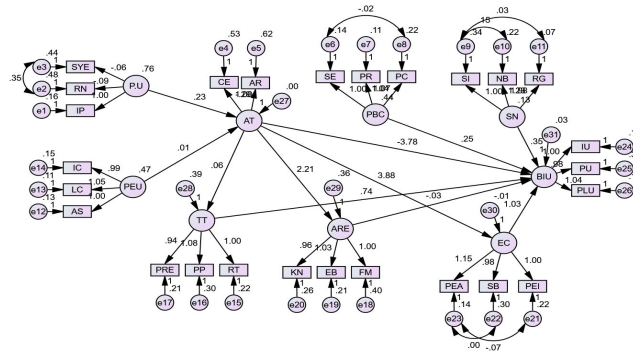

**Fig. 2.** SEM analysis Results

**Table 6**  
SEM analysis Results

	Estimate	S.E.	C.R.	P
<b>Direct Effects</b>				
BIU ← SN	0.347	0.084	4.132	***
BIU ← PBC	0.25	0.029	8.552	***
BIU ← AT	-3.779	8.032	-0.471	0.638
BIU ← TT	0.744	0.046	16.051	***
BIU ← ARE	-0.028	0.032	-0.849	0.396
BIU ← EC	1.028	2.093	0.491	0.623
AT ← PU	0.227	0.068	3.367	***
AT ← PEU	0.005	0.007	0.734	0.463
<b>Indirect Effects</b>				
AT → TT → BIU	.042	0.008	11.89	***
AT → ARE → BIU	-0.062	0.014	-4.203	***
AT → EC → BIU	3.986	1.5237	2.6160	***

PU = Perceived Usefulness; PEU=Perceived Ease of Use, PBC = Perceived Behavioral Control, SN=Subjective Norm, TT=Trust in Technology, ARE=Awareness of Renewable Energy, EC=Environmental Concerns, BIU=Behavioral intention to use, AT=Attitude

The relationship between the study variables indicates that SN significantly positively affects BIU ( $\beta = 0.347$ ,  $p=0.000$ ), confirming H1. PBC positively influences BIU ( $\beta = 0.025$ ,  $p=0.000$ ), supporting H2. The results indicated that AT has an insignificant negative influence on BIU ( $\beta = -3.779$ ,  $p=0.638$ ), rejecting H3. Trust was found to have a positive significant effect on BIU ( $\beta = 0.744$ ,  $p=0.000$ ) supporting H4. ARE was found to have a negative insignificant influence on BIU ( $\beta = -0.028$ ,  $p=0.396$ ), rejecting H5. EC was found to have a positive insignificant effect on BIU ( $\beta = 1.028$ ,  $p=0.623$ ), hence rejecting H6. PU significantly influences AT ( $\beta = 0.227$ ,  $p=0.000$ ), hence accepting H7. PEU was found to have a significant and positive influence on AT ( $\beta = 0.005$ ,  $p=0.463$ ), hence supporting H8. The results for mediation indicated that TT mediates the effects of AT on BIU ( $\beta = 0.042$ ,  $p=0.000$ ); ARE significantly and negatively mediates the effects of AT on BIU ( $\beta = -0.062$ ,  $p=0.000$ ); as well, EC significantly mediates the effects of AT on BIU ( $\beta = 3.986$ ,  $p=0.000$ ). As a result, H9a, H9b and H9c were supported (see Fig. 2).

## 5. Discussion

The impact of subjective norms on the behavioral intention of using PV panel cleaning robots for institutional PV panel users was evaluated. The results brought to light that subjective norm had significant and positive effects on BIU ( $\beta = 0.326$ ,  $p=0.000$ ). This meant that subjective norm aspects such as social influence, normative beliefs, and reference group influence were critical in influencing institutional behaviors regarding the use of these robots. Influence from other related, collaborating, or competing institutions could affect the behavioral intention towards their usage. These outcomes of the study agree with that of Darmansyah et al. (2020) that had the view that social influencing is a determining factor in the process of adoption and use of banking technologies. A study by Troise et al. (2021) also showed that subjective norms had a significant impact on the process of people adopting meal delivery services. Another aspect worth discussing was the effect of perceived behavioral control. It was found to be a significant determinant in the adoption and use of PV panel cleaning robots. The aspects of perceived behavioral control evaluated included self-efficacy, perceived resources and support, and perceived complexity. If these aspects increased, then the adoption of solar panel cleaning robots also increased. These results align with Sultan et al. (2020) whose study found that the intention-behavior gap might be closed through perceived behavioral control. The difference between people's intentions and actual behavior towards eating organic food was less when people had a high conviction in their capacity to control such behavior. The effects of attitude were conducted to evaluate the impact of attitude on the institution's behavioral intention to use solar panel cleaning robots. The results indicated that AT has an insignificant negative influence on BIU ( $\beta = 3.215$ ,  $p=0.579$ ). These results indicated that attitudes such as cognitive evaluation and affective response did not affect institutional behavior toward using PV panel cleaning robots. These findings did not agree with other researchers, such as Kumar et al. (2020), who investigated how self-efficacy, subjective norms and WhatsApp usage habits influenced their intentions. They discovered that the behavioral intention to utilize mobile learning was highly affected by a positive attitude driven by self-efficacy and subjective norms. The effect of trust in solar panel cleaning robots' adoption was another aspect of consideration. Trust was found to have a high ( $\beta = 0.761$ ) and significant ( $p=0.000$ ) influence of intention to adopt this technology among the institutional users. The aspects of trust that were evaluated in this case included perceived reliability, perceived privacy and security, and reputation. If these aspects were improved, then the tendency to adopt the cleaning robots would be improved. These findings echo that of Zhou et al. (2019) whose findings indicate that trust is a critical component in the adoption of telehealth services. Another aspect of consideration was the effect of awareness of renewable energy in the process of adoption and use of solar panel cleaning robots. Centrally to other aspects, awareness was found to have a negative influence, which was insignificant. To this study, the aspects evaluated included knowledge about renewable energy, awareness of environmental benefits, and familiarity with renewable energy. These aspects were not significantly influential. These findings contrasted with that of Irfan et al. (2021), who indicated that renewable energy people's awareness and opinions were significant as far as technology adoption is concerned. They indicated that as people learn more about the technology advantages and uses, the higher the chances of using the technology. The impact that environmental concerns have on institutional behavioral intent to use solar panel cleaning robots was evaluated. According to the results, environmental concern positively affects BIU ( $\beta = 0.887$ ,  $p=0.555$ ). These findings implied that environmental problems such as pro-environmental attitudes, sustainable behavior engagement, and perceived environmental impact positively correlate with institutions' behavioral intention to use PV panel cleaning robots. However, this relationship has no significant effect. These results disagreed with Mayerl and Best (2019), whose results showed that behavioral intention and environmental concern had a beneficial relationship, such that those more concerned about the environment are more likely to adopt pro-environmental habits and take steps to save the environment. The impacts of perceived usefulness on the attitude of the institutions to use solar panel cleaning robots. The results indicated that PU significantly positively influences AT ( $\beta = 0.223$ ,  $p=0.000$ ). These results meant that if the institutions captured aspects of perceived usefulness such as system effectiveness, relevance to the needs, and impact on productivity, their attitudes towards using PV panel cleaning robots would be enhanced. These findings are supported by literature, from the fact that perceived usefulness is a significant variable towards attitude as a system, instruction, product, or service that people find beneficial tends to influence their attitudes favorably, suggesting that a critical factor affecting people's general attitudes and levels of pleasure is the perceived usefulness of a specific characteristic (Kaur, 2020). The effect of perceived ease of use on the institutions' attitude towards using PV panel cleaning robots was evaluated. The results demonstrated that perceived ease of use significantly and positively influences AT ( $\beta = 0.010$ ,  $p=0.221$ ). It conveys that an institution's improvement in perceived ease of use, such as interface complexity, learning curve, and assistance and support, would result in a positive attitude towards the solar panel cleaning robots. A further analysis was conducted to investigate how the effect of institutions' attitudes on behavior and intention to



use solar cleaning robots was mediated by other factors such as trust in technology, awareness of renewable energy, and environmental concern. The results reveal that trust in technology did not mediate the effect of attitude on behavior and intention to use PV cleaning robots. In contrast, awareness of renewable energy and environmental concerns significantly mediate the impact of attitude on individual users' behavior toward the use of solar panel cleaning robots. It suggested that aspects of awareness of renewable energy (knowledge about renewable energy, awareness of environmental benefits, and familiarity with renewable energy) and aspects of environmental concern (pro-environmental attitudes, sustainable behavior engagement, and perceived environmental impact) affected the PV panel users' perspectives and attitudes towards the adoption and uses of PV cleaning robots.

### *5.1 Theoretical and Managerial Implications*

The first theoretical contribution of this study is that it contributes significantly to the existing literature on renewable energy adoption, particularly about the adoption of PV panel cleaning robots. By adopting an institutional perspective, the study expands the understanding of factors influencing the intention to use this technology. Using the C-TAM-TPB model, the study highlights the importance of subjective norms, perceived behavioral control, trust in technology, and perceived usefulness in influencing the institutions, firms, and organizations' use of PV panel cleaning robots. The study further highlights the complexity of the factors at play in influencing the usage of solar technology. In this case, the understanding is expounded by demonstrating how trust in technology, awareness of renewable energy, and environmental concerns mediate the relationship between attitudes and intention to use PV panel cleaning robots. More importantly, this study contributes to a broader institutional theory perspective by demonstrating the significance of institutional pressures and normative expectations, as explicitly reflected through subjective norms and trust in technology. They are critical in shaping organizational and institutional behaviors toward adopting new technologies.

### *5.2 Managerial Implications*

The study recommends several practical implications that could help managers and stakeholders in the energy sector boost renewable energy adoption as a source of clean energy. First, this research highlights the importance of building trust in renewable energy technologies. This is developed through the significantly and positively established effects of trust on technology on the behavior of people who intend to use PV panel technologies. As such, it is recommended that manufacturers and service providers of PV panel cleaning robots prioritize building and maintaining trust. This can be achieved by ensuring the reliability and effectiveness of their technologies, providing transparent information, and offering robust after-sales support. Secondly, this study points out that the attitude towards technology acts as a barrier and should be urgently and effectively addressed. The findings of this study indicated that attitude is a barrier that negatively influences the adoption of PV panel cleaning robots. The authors suggest potential users may have reservations or need more information to form a positive outlook toward solar panel cleaning robots. Educational initiatives that accurately convey the benefits and efficiency gains from using such technologies and address any misconceptions could be pivotal in positively shifting attitudes. Thirdly, considering the major benefits of using solar energy, including a reduction in environmental pollution, this study suggests that national and local governments should adopt and implement policy support. Policymakers should consider offering incentives or subsidies to adopt PV panel cleaning robots, especially for organizations and institutions making significant contributions to renewable energy generation. Such policies could alleviate initial cost concerns and accelerate technology adoption.

## **6. Conclusions**

The objective of this research was threefold: a) to study the intention to use PV panel cleaning robots among institutional users in Thailand; b) to analyze the direct and indirect factors that influence the intention to use PV panel cleaning robots among institutional users in Thailand; and c) to develop the intention to use PV panel cleaning robots in Thailand - extended C-TAM-TPB model. Various interesting findings were obtained. Behavioral intention to use PV panel cleaning robots among institutional users was significantly influenced by subjective norms, perceived behavioral control, and trust in technology. The attitude towards the adoption of PV panel cleaning robots was influenced by perceived usefulness. Also, the research found that the effect of the attitude of institutions towards behavioral intention towards PV panel cleaning robots was significantly mediated by trust in technology, awareness of renewable energy, and environmental concerns.

The research highlighted the importance of expanding the understanding of factors that influence intention to use this technology by emphasizing the importance of subjective norms, perceived behavioral control, trust in technology, and perceived usefulness. The study recommended the importance of building trust in renewable energy technologies through public awareness of the reliability and effectiveness of their technologies, providing transparent information, and offering robust after-sales support. Educational initiatives that accurately convey the benefits and efficiency gains from using such technologies and address any misconceptions could be pivotal in positively shifting attitudes. The research also recommended that the government support adopting renewable energy technologies.

## References

- Akther, T., & Nur, T. (2022). A model of factors influencing COVID-19 vaccine acceptance: A synthesis of the theory of reasoned action, conspiracy theory belief, awareness, perceived usefulness, and perceived ease of use. *PLoS One*, *17*(1), e0261869.
- Al-Marri, W., Al-Habaibeh, A., & Watkins, M. (2018). An investigation into domestic energy consumption behaviour and public awareness of renewable energy in Qatar. *Sustainable Cities and Society*, *41*, 639-646.
- Angelia, A., Panjaitan, E. S., & Yunis, R. (2021). Effect of attitude on mobile banking acceptance using extended UTAUT model. *Jurnal Mantik*, *5*(2), 1006-1013.
- Aschwanden, D., Strickhouser, J. E., Sesker, A. A., Lee, J. H., Luchetti, M., Terracciano, A., & Sutin, A. R. (2021). Preventive behaviors during the COVID-19 pandemic: Associations with perceived behavioral control, attitudes, and subjective norm. *Frontiers in Public Health*, *9*, 662835.
- Banerjee, S., & Ho, S. S. (2020). Applying the theory of planned behavior: Examining how communication, attitudes, social norms, and perceived behavioral control relate to healthy lifestyle intention in Singapore. *International Journal of Healthcare Management*, *13*(1), 496-503.
- Bundschuh, J., Kaczmarczyk, M., Ghaffour, N., & Tomaszewska, B. (2021). State-of-the-art of renewable energy sources used in water desalination: Present and future prospects. *Desalination*, *508*, 115035.
- Chao, C.M. (2019). Factors determining the behavioral intention to use mobile learning: An application and extension of the UTAUT model. *Frontiers in Psychology*, *10*, 1652.
- Chen, L., & Aklikokou, A.K. (2020). Determinants of E-government adoption: testing the mediating effects of perceived usefulness and perceived ease of use. *International Journal of Public Administration*, *43*(10), 850-865.
- Chen, Y., Liu, Y., Tian, Z., Dong, Y., Zhou, Y., Wang, X., & Wang, D. (2019). Experimental Study on the Effect of Dust Deposition on Photovoltaic Panels. *Energy Procedia*, *158*, 483-489.
- Cialdini, R. B., & Goldstein, N. J. (2004). Social influence: compliance and conformity. *Annual Review of Psychology*, *55*, 591-621.
- Colak, H. E., Memisoglu, T., & Gercek, Y. (2020). Optimal site selection for solar photovoltaic (PV) power plants using GIS and AHP: A case study of Malatya Province, Turkey. *Renewable Energy*, *149*, 565-576.
- Cruz, S.M., & Manata, B. (2020). Measurement of environmental concern: A review and analysis. *Frontiers in Psychology*, *11*, 363.
- Darmansyah, D., Fianto, B. A., Hendratmi, A., & Aziz, P. F. (2020). Factors determining behavioral intentions to use Islamic financial technology: Three competing models. *Journal of Islamic Marketing*, *12*(4), 794-812.
- Davis, F.D. (1989). Perceived usefulness, perceived ease of use, and user acceptance of information technology. *MIS Quarterly*, *13*(3), 319-340.
- Fitriani, S., Horsch, C., Beun, R. J., Griffioen-Both, F., & Brinkman, W. P. (2021). Factors affecting user's behavioral intention and use of a mobile-phone-delivered cognitive behavioral therapy for insomnia: A small-scale UTAUT analysis. *Journal of Medical Systems*, *45*, 1-18.
- Fornell, C., & Larcker, D. F. (1981). Evaluating structural equation models with unobservable variables and measurement error. *Journal of Marketing Research*, *18*(1), 39-50.
- Gambetta, D. (Ed.). (1988). *Making and breaking cooperative relations*. Blackwell.
- Gansser, O. A., & Reich, C. S. (2021). A new acceptance model for artificial intelligence with extensions to UTAUT2: An empirical study in three segments of application. *Technology in Society*, *65*, 101535.
- Giraldo, M.C.B., Benjumea-Arias, M.L., Valencia-Arias, A., & Montoya-Restrepo, I.A. (2021). Factors determining the use and acceptance of mobile banking in Colombia. *Journal of Telecommunications and the Digital Economy*, *9*(4), 44-74.
- Glunz, S. W., Preu, R., & Biro, D. (2012). Crystalline silicon solar cells: state-of-the-art and future developments. *Comprehensive Renewable Energy*, *1*, 353-387.
- Holotová, M., Nagyová, L., & Holota, T. (2020). The impact of environmental responsibility on changing consumer behaviour – sustainable market in Slovakia. *Economics and Sociology*, *13*(3), 84-96.
- Hosseini, S.E., & Wahid, M.A. (2020). Hydrogen from solar energy, a clean energy carrier from a sustainable source of energy. *International Journal of Energy Research*, *44*(6), 4110-4131.
- Huang, C. (2020). The influence of self-efficacy, perceived usefulness, perceived ease of use, and cognitive load on students' learning motivation, learning attitude, and learning satisfaction in blended learning methods. Proceedings of the 2020 3rd International Conference on Education Technology Management.
- Irfan, M., Hao, Y., Ikram, M., Wu, H., Akram, R., & Rauf, A. (2021). Assessment of the Public Acceptance and Utilization of Renewable Energy in Pakistan. *Sustainable Production and Consumption*, *27*, 312-324.
- Jurasz, J., Canales, F. A., Kies, A., Guezgouz, M., & Beluco, A. (2020). A review on the complementarity of renewable energy sources: Concept, metrics, application and future research directions. *Solar Energy*, *195*, 703-724.
- Kaur, M. (2020). Analyzing the relationship of perceived ease of use, perceived usefulness, attitude towards usage and behavioural intention to use e-government services in state of Punjab. *International Journal of Computer Applications*, *175*(36), 8-15.
- Kawamoto, H. (2019). Electrostatic cleaning equipment for dust removal from soiled solar panels. *Journal of Electrostatics*, *98*, 11-16.

- Keni, K. (2020). How perceived usefulness and perceived ease of use affecting intent to repurchase? *Jurnal Manajemen*, 24(3), 481-496.
- Kumar, J.A., Bervell, B., Annamalai, N., & Osman, S. (2020). behavioral intention to use mobile learning: Evaluating the role of self-efficacy, subjective norm, and WhatsApp use habit. *IEEE Access*, 8, 208058-208074.
- Kumar, S., & Sreen, N. (2020). Role of internal and external values on green purchase. In *Green marketing as a positive driver toward business sustainability* (pp. 158-185). IGI Global.
- Liang, L., Lu, L., & Su, L. (2023). The impact of industrial robot adoption on corporate green innovation in China. *Scientific Reports*, 13(1), 1-14.
- Liang, P., & Chi, Y. (2021). Influence of perceived risk of blockchain art trading on user attitude and behavioral intention. *Sustainability*, 13(23), 13470.
- Maciaszczyk, M., Czechowska-Kosacka, A., Rzepka, A., Lipecki, T., Łazuka, E., & Wlaź, P. (2022). Consumer Awareness of Renewable Energy Sources: The Case of Poland. *Energies*, 15(22), 8395.
- Manrai, R., & Gupta, K. P. (2020). Integrating UTAUT with trust and perceived benefits to explain user adoption of mobile payments. In: Kapur, P.K., Singh, O., Khatri, S.K., Verma, A.K. (eds) *Strategic system assurance and business analytics*. Asset Analytics. Springer, Singapore, pp 109–121
- Mayerl, J., & Best, H. (2019). Attitudes and behavioral intentions to protect the environment: How consistent is the structure of environmental concern in cross-national comparison? *International Journal of Sociology*, 49, 27 - 52.
- McKnight, D.H. (2005). Trust in information technology. *The Blackwell Encyclopedia of Management*, 7, 329-331.
- Mofijur, M., Mahlia, T. M., Silitonga, A. S., Ong, H. C., Silakhori, M., Hasan, M. H., Putra, N., & Rahman, S. M. (2019). Phase change materials (PCM) for solar energy usages and storage: An overview. *Energies*, 12(16), 3167.
- Mukhtarov, S., Aliyev, J., Borowski, P.F., & Disli, M. (2023). Institutional quality and renewable energy transition: Empirical evidence from Poland. *Journal of International Studies*, 16(3), 208-218.
- Namazov, Rashad & Popal, X. (2023). The role of solar panels in energy production. *Ecoenergetics*, 4, 51-55, 2022.
- Nasirov, S., Agostini, C., Silva, C., & Caceres, G. (2018). Renewable energy transition: a market-driven solution for the energy and environmental concerns in Chile. *Clean Technologies and Environmental Policy*, 20, 3-12.
- Nguyen, T. T., Thi Thu Truong, H., & Le-Anh, T. (2023). Online purchase intention under the integration of theory of planned behavior and technology acceptance model. *SAGE Open*.
- Nijse, J.M., Mercure, F., Ameli, N., Larosa, F., Kothari, S., Rickman, J., Vercoulen, P., & Pollitt, H. (2023). The momentum of the solar energy transition. *Nature Communications*, 14(1), 6542.
- Nunnally J.C., Bernstein I.H. (1994). *Psychometric theory* (3rd ed.). New York, NY: McGraw-Hill.
- Obaideen, K., AlMallahi, M. N., Alami, A. H., Ramadan, M., Abdelkareem, M. A., Shehata, N., & Olabi, A. G. (2021). On the contribution of solar energy to sustainable developments goals: Case study on Mohammed bin Rashid Al Maktoum Solar Park. *International Journal of Thermofluids*, 12, 100123.
- Okpala, I., Nnaji, C., & Awolusi, I. (2022). Wearable sensing devices acceptance behavior in construction safety and health: assessing existing models and developing a hybrid conceptual model. *Construction Innovation*, 22(1), 57-75.
- Olayiwola, O., Elsdén, M., & Dhimish, M. (2024). Robotics, Artificial Intelligence, and Drones in Solar Photovoltaic Energy Applications—Safe Autonomy Perspective. *Safety*, 10(1), 32.
- Patil, P.A., Bagi, J.S., & Wagh, M.M. (2017, August). A review on cleaning mechanism of solar photovoltaic panel. In 2017 International Conference on Energy, Communication, Data Analytics and Soft Computing (ICECDS) (pp. 250-256). IEEE.
- Rashid, M., Yousif, M., Rashid, Z., Muhammad, A., Altaf, M., & Mustafa, A. (2023). Effect of dust accumulation on the performance of photovoltaic modules for different climate regions. *Heliyon*, 9(12).
- Sattari, A., Abdekhoda, M., & Zarea Gavgani, V. (2017). Determinant factors affecting the web-based training acceptance by health students, applying UTAUT model.
- Schumacker, R. E., & Lomax, R. G. (2004). *A beginner's guide to structural equation modeling*. Psychology press.
- Segars, A. H. (1997). Assessing the unidimensionality of measurement: A paradigm and illustration within the context of information systems research. *Omega*, 25(1), 107-121.
- Shiau, W. L., & Chau, P. Y. (2016). Understanding behavioral intention to use a cloud computing classroom: A multiple model comparison approach. *Information and Management*, 53(3), 355-365.
- Shukla, V., & Kumar, N. (Eds.). (2020). *Environmental concerns and sustainable development: volume 1: air, water and energy resources* (pp. 1-351). Springer Singapore.
- Straka, M., Oláh, J., & Kassakorn, N. (2021). Impact of Green Supply Chain Integration on SMEs' Technological and Economic Performance. *Global Journal of Entrepreneurship and Management*, 2(1), 12-30.
- Sun, D., & Böhringer, K. F. (2020). An active self-cleaning surface system for photovoltaic modules using anisotropic ratchet conveyors and mechanical vibration. *Microsystems and Nanoengineering*, 6(1), 87.
- Teo, T., Zhou, M., Fan, A. C. W., & Huang, F. (2019). Factors that influence university students' intention to use Moodle: A study in Macau. *Educational Technology Research and Development*, 67, 749-766.
- Troise, C., O'Driscoll, A., Tani, M., & Prisco, A. (2021). Online food delivery services and behavioural intention—a test of an integrated TAM and TPB framework. *British Food Journal*, 123(2), 664-683.
- Tseng, T. H., Lin, S., Wang, Y. S., & Liu, H. X. (2022). Investigating teachers' adoption of MOOCs: the perspective of UTAUT2. *Interactive Learning Environments*, 30(4), 635-650.

- Wall, W. P., Khalid, B., Urbański, M., & Kot, M. (2021). Factors influencing consumer's adoption of renewable energy. *Energies*, *14*(17), 5420.
- Xue, L., Rashid, A. M., and Ouyang, S. (2024). The Unified Theory of Acceptance and Use of Technology (UTAUT) in higher education: A systematic review. *SAGE Open*.



© 2024 by the authors; licensee Growing Science, Canada. This is an open access article distributed under the terms and conditions of the Creative Commons Attribution (CC-BY) license (<http://creativecommons.org/licenses/by/4.0/>).