

Uncertain Supply Chain Management

homepage: www.GrowingScience.com/uscm

I-deals on the retention of human talent in health networks in Satipo, Peru

Hansel Renato Puente Yance^a, Rosibel Amparo Arauco Prado^a and Wagner Vicente-Ramos^{a*}

^aUniversidad Continental, Peru

ABSTRACT

Article history:

Received January 9, 2024

Received in revised format

February 18, 2024

Accepted April 9 2024

Available online

April 9 2024

Keywords:

I-deal

Talent retention

Organizational commitment

Health network

Work autonomy

The objective of the research was to determine if there is an influence of i-deals on the retention of human talent in the health networks of Satipo, Peru. The study was carried out from a quantitative approach, with a correlational-non-experimental-translational design. A questionnaire was administered to 308 workers who negotiated one or more idiosyncratic agreements between December 2023 and February 2024. Using the structural equation model, it was obtained that the i-deals of work content (i-TC) and development (i-D) have a higher level of influence on the retention of human talent ($p < 0.05$), generating a high commitment to the organization; based on the appropriate job assignment to employees according to technical and soft skills, and aligned with their personal interests. On the other hand, flexibility (i-F) and financial (i-FI) i-deals do not influence the retention of human talent, because the remuneration is not aligned with the required professional skills. It is concluded that for the public health sector, employees prefer to have autonomy in the way they perform their work, opportunities for professional specialization rather than financial incentives.

© 2024 by the authors; licensee Growing Science, Canada.

1. Introduction

Today's work environment demands high-quality relationships between employees and the organization (Kang & Sung, 2019). There are several factors such as the context of the organization, the ideal type of incentive, the specific needs of the individual, the personality of the individual and the employer, etc. influence the extent to which pending agreements impact variables such as productivity, competitiveness, and talent retention (Rofcanin et al., 2021). Idiosyncratic contracts, commonly known as i-deals, are individualized agreements on terms of employment between workers considered particularly valuable or key and their employers, the product of negotiation (Rousseau, 2001). The increase in i-deals in organizations has been stimulated by changes in the employment system, work modalities and forms of hiring (Rentería & Vesga, 2019) that have occurred in recent decades and that have challenged the concept of career and the relationship between employers and employees, as well as the change in the attitudes and expectations of men and women towards work (Benko & Weisberg, 2007) emphasizing the active role of employees in the development of their own careers and an increasing demand for proactivity in workers. On the one hand, the new economic realities demand that organizations become more flexible and better adapt to the changing market circumstances through which they try to build a flexible workforce, which in turn demands that organizations can no longer offer universalist schemes, i.e., one-size-fits-all approaches (Rentería & Malvezzi, 2018).

Idiosyncratic contracts were applied with greater emphasis during the coronavirus disease 2019 (COVID-19) pandemic, where nurses played an important role on the front lines of care. During the COVID-19 pandemic, the findings of Schoberer et al. (2022) suggested that nurses be assigned additional tasks. Zhan et al. (2020) confirmed that the main variables promoting stress for nurses were doing more work with limited time and resource constraints. A Danish study also found that nurse managers were performing roles they did not originally perform before the COVID-19 pandemic (Hølge-Hazelton et al., 2021). Increased job duties and responsibilities resulted in nurses negotiating their responsibilities due to the COVID-19 pandemic.

* Corresponding author

E-mail address wvicente@continental.edu.pe (W. Vicente-Ramos)

ISSN 2291-6830 (Online) - ISSN 2291-6822 (Print)

© 2024 by the authors; licensee Growing Science, Canada.

doi: 10.5267/j.uscm.2024.4.008

In doing so, this helped increase nurses' engagement levels. This was confirmed by Zhang et al. (2021) stating that nurses' work engagement increased during the pandemic due to the self-dedicated nature of the nursing profession.

Rousseau (2001) explains that the increase in i-deals is due to the high demand for workers in knowledge-based occupations with distinctive competencies in a hyper-competitive market, which leads to workers having greater power to negotiate working conditions that suit their tastes, preferences and needs. Aspects such as people's proactivity and responsibility for their own careers, the value of distinctive skills in labour markets, among other aspects, influence people's employability and in turn are factors that make it possible to negotiate i-deals (Orejuela, 2014).

Therefore, the objective of this survey is to study the impact of i-deals on the retention of human talent in the Health Sector - Minsa of the province of Satipo of the Department of Junín in Peru.

2. Literary Review

2.1. I-deals

According to Tena (2002), the term i-deals was coined by social scientists and began to appear in the literature in the late 1950s. Rousseau et al. (2016) describe i-deals as special conditions that an employer provides to an individual employee, conditions that are different from those that their co-workers have. Hornung et al. (2008) emphasize that these special conditions must be unique compared to those of co-workers performing similar work. Bal and Lub (2018) add to this definition by pointing out that the term i-deal suggests that it is ideal, since after its negotiation, both parties to the agreement, the employee and the organization, must reap benefits. I-deals are negotiated individually between employee and organization, i.e., the collective agreement of special working conditions that can be part of an employee benefits policy is not considered an i-deal (Rousseau, 2005). Secondly, i-deals are heterogeneous, as the characteristics of what is agreed upon are different for each employee. I-deals, not being part of a standardized policy or practice in the organization, will depend on the characteristics or needs of those who negotiate (Greenberg et al., 2004). Third, i-deals benefit both the employee and the organization. On the one hand, employees, because it satisfies personal needs, can facilitate aspects such as well-being, work-life balance, career development, among others. On the other hand, it benefits the organization because it facilitates the attraction, retention, and motivation of employees who are valuable to the organization, which is reflected in greater productivity. This mutual benefit places i-deals in a different position than corruption, favoritism, and preferential treatment, as it is based on the legitimacy of shared benefits (Lai et al., 2009).

Development I-deals

The I-deals of Development is significant because the employee can benefit in different aspects such as training, specialties, work incentives and professional development. These opportunities from employer to employee allow the development of competencies, skills, aptitudes and knowledge, thus generating work motivation (Rousseau et al., 2016).

Flexibility I-deals

According to Lee and Hui (2011), flexibility i-deals particularize work schedules and modalities according to the needs of the worker; as they can continue to work despite difficulties with schedule and/or location, allowing them to continue exploiting their potential in the organization. The advantage for the organization lies primarily in the retention of workers nearing retirement, allowing the organization to leverage their knowledge and experience for longer (Rousseau et al., 2016).

Work Content I-deals

Work content i-deals can include flexibility in working hours, assignment of specific projects, personalized professional development opportunities, among other aspects. These arrangements can be beneficial for both employees and employers, as they can increase employee job satisfaction, motivation, and productivity (Orejuela, 2014). The advantage for the employer is to have employees with greater commitment and loyalty to the organization.

Financial I-deals

Regarding financial i-deals, they benefit the employer by being an effective resource such as bonuses for punctuality, meeting goals, good work performance, etc. in order to retain star workers who will be of great use in the organization. On the employee's side, they will benefit from an increase in their income (Rousseau et al., 2016).

2.2. Human Talent Retention

Chiavenato (2009) argues that, at the organizational level, an organization's employees begin to be recognized as human talent when they begin to make contributions of significant value. On the other hand, Lozano (2007) describes this concept as the combination of skills and competencies that a person has perfected and that are used to carry out innovations. Effective human talent management involves hiring and selecting the right people, followed by their direction, development, supervision, and compensation. As a result of proper management, these employees develop a sense of belonging and commitment to the organization, and in turn, perform their duties in a productive and high-quality manner. This allows the company to achieve its organizational goals (Vallejo, 2016). Human talent retention refers to the strategies and practices employed to keep talented and valuable employees within the company, rather than losing them to competition or other opportunities (Miranda, 2016).

Some common strategies for human talent retention include: professional development and growth opportunities, competitive compensation, positive organizational culture, work-life balance, recognition and appreciation, as well as open communication.

Commitment to the organization

It refers to the degree to which an employee identifies with the goals, values, and culture of the company they work for, as well as their willingness to contribute to the success of the organization. This dimension of engagement is critical to the productivity and well-being of both the individual and the company as a whole (Robbins & Judge, 2009).

Loyalty to the organization

Gómez, Santofimio, and Segura (2007) define loyalty as a quality present in people with a strong sense of duty, responsibility, and capacity for altruism and detachment. It is an important component in organizational culture and can contribute to well-being and cohesion within the company.

3. Research Model and Hypothesis

I-deals, as an independent variable, have the following indicators:

- a) Work Content I-Deals (i-CT): Tasks that match my skills (i-CT1), tasks that suit my personal interests (i-CT2), tasks that I personally find motivating (i-CT3), full autonomy in the way I do my job (i-CT4), partial autonomy in the way I do my work (i-CT5), limited autonomy in the way I do my work (i-CT6).
- b) Development I-Deals (I-D): Training Training Opportunities (i-D1), Specialization Training Opportunities (i-D2), Supplemental Training Opportunities (I-D3), Personalized Career Plan That Fits My Personal Goals (I-D4), Work Assignments, That Enhance My Career Development (i-D5), Challenging Performance Goals (i-D6).
- c) Flexibility I-deals (i-F): working hours that meet my personal needs (i-F1), flexibility in the time of entry and exit from work (i-F2), flexibility of time to attend to personal matters (i-F3), possibility of carrying out my work completely outside the workplace (i-F4), possibility of carrying out my work between the workplace and outside the workplace with previously established days in each case (i-F5), the possibility of carrying out my work between the workplace and outside the workplace with the freedom to choose which days to use in each case (i-F6).
- d) Financial I-deals (i-FI): Salary commensurate with my professional competencies (i-FI1), benefits package that fits my personal needs (i-FI2), financial incentives for performance (i-FI3)

Retention of human talent as a dependent variable has the following indicators:

- a) Commitment to the organization (R-CO): I feel identified with the organizational objectives (R-CO1), I feel satisfied when my work contributes to the good of the organization (R-CO2), I feel committed to giving an extra effort if necessary, for the good of the organization (R-CO3).
- b) Loyalty to the organization (R-LO): I want to continue working in this organization (R-LO1), if I am offered a job offer with similar conditions, I would prefer to continue working in that organization (R-LO2), if I am offered a job offer with a higher salary than the current one, I would prefer to continue working in this organization (R-LO3), I feel satisfied to have worked for all this time in the organization (R-LO4).

From which the following conceptual model and hypothesis are established.

H₁: *The work content i-deals (i-CT) generate a positive influence on the Commitment to Organization (R-CO) of the workers of the Health Networks of Satipo - Peru.*

H₂: *The i-deals of work content (i-CT) generate a positive influence on the Loyalty to the organization (R-LO) of the workers of the Health Networks of Satipo - Peru.*

H₃: *The development i-deals (i-D) generate a positive influence on the Commitment to the Organization (R-CO) of the workers of the Health Networks of Satipo - Peru.*

H₄: *Development i-deals (i-D) generate a positive influence on the Loyalty to the Organization (R-LO) of the workers of the Health Networks of Satipo - Peru.*

H₅: *Flexibility i-deals (i-F) generate a positive influence on the Commitment to Organization (R-CO) of the workers of the Health Networks of Satipo - Peru.*

H₆: *Flexibility i-deals (i-F) generate a positive influence on the Loyalty to the Organization (R-LO) of the workers of the Health Networks of Satipo - Peru.*

H₇: *Financial i-deals (i-FI) generate a positive influence on the Commitment to Organization (R-CO) of the workers of the Health Networks of Satipo - Peru.*

H₈: *Financial i-deals (i-F) generate a positive influence on the Loyalty to the Organization (R-LO) of the workers of the Health Networks of Satipo - Peru.*

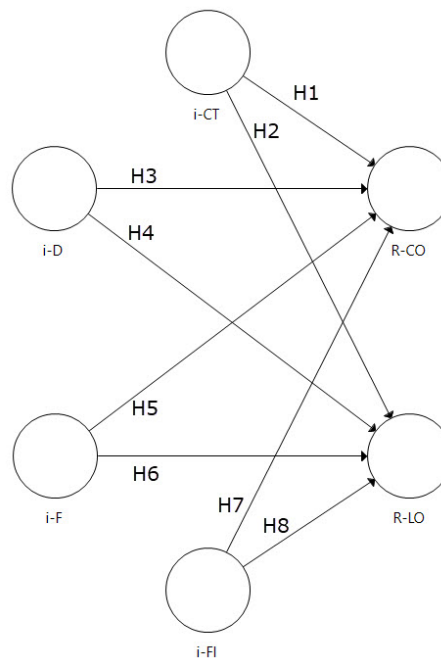

Fig. 1. Conceptual model and hypotheses

4. Method

This research was correlational, since according to Bernal (2010) it allows us to measure the degree of relationship between the research variables, and our general objective of study is to analyze the impact of idiosyncratic contracts (independent variable) on talent retention (dependent variable), and this type of study will allow us to achieve this objective.

Population and sample

In the present study, the set of elements that make up the population are all the workers (health personnel and administrative personnel) linked to the Health Networks of Satipo - Peru, between December 2023 and February 2024. The population for this study is made up of 1 162 workers in this area, according to information obtained from the Ministry of Labor and Employment Promotion.

The sample size for this research was 308 workers, which was made up of 63.96% women and 36.04% men; The sample has the same characteristics defined in the population, and was calculated with a confidence level of 95% and a margin of error of 5%.

Data collection instrument

The structure of the data collection instrument has a total of 27 items; Regarding the first variable, "i-deals", 20 items were considered to be measured with the following scale: 1 Not at all benefited, 2 Slightly benefited, 3 Moderately benefited, 4 Significantly benefited and 5 Totally benefited. Regarding the second variable, "retention of human talent", 7 items were used to measure it with the following scale: 1 Strongly disagree, 2 Disagree, 3 Neither agree nor disagree, 4 Agree and 5 Strongly agree.

The validation and reliability of the data collection instrument was determined using Cronbach's alpha coefficient (0.89).

5. Results

5.1. Assessment of the Measurement Model

Table 1 shows the measurement analysis of the model, based on the reliability and validity of the measurement scales. Regarding reliability, the internal consistency of the scales is evidenced by the Cronbach Alpha value (between 0.866 and 0.940) and the composite reliability (between 0.908 and 0.952). With respect to convergent validity, all factor loads are above 0.800. Likewise, all scales have percentages of mean variance extracted (AVE) greater than 70%. The discriminant validity of the construct was tested by the Fornell Larcker criteria, which verifies the independence of each of the scales, considering that the square root of the AVE is greater than the correlations with the rest of the scales. In all cases, the assumption was met.

Table 1

Results of the model measurement analysis

Variables	Cronbach alpha	Composite reliability	Factor loads (range)	Average variance extracted (AVE)	Discriminant Validity
i-CT	0.904	0.929	0.810 – 0.879	0.723	0.850
i-D	0.940	0.952	0.829 – 0.901	0.769	0.877
i-F	0.923	0.940	0.819 – 0.873	0.722	0.849
i-FI	0.876	0.923	0.853 – 0.937	0.799	0.894
R-CO	0.868	0.919	0.879 – 0.906	0.790	0.889
R-LO	0.866	0.908	0.743 – 0.892	0.713	0.844

As shown in Fig. 2, an R² greater than 0.200 was obtained, which is significant, showing that the model significantly explains the variance of the conceptual constructs of the dependent variable.

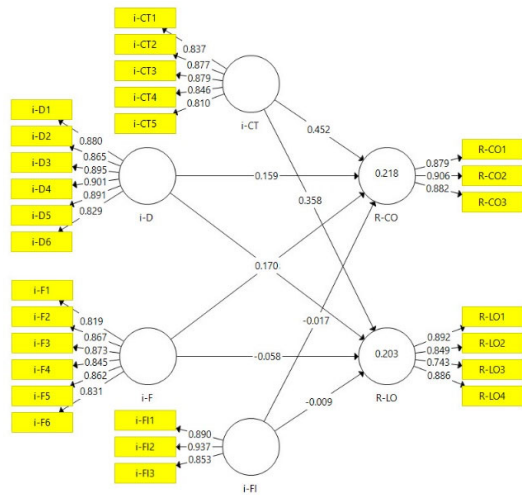

Fig. 2. Results for the hypothesized model with structural equations

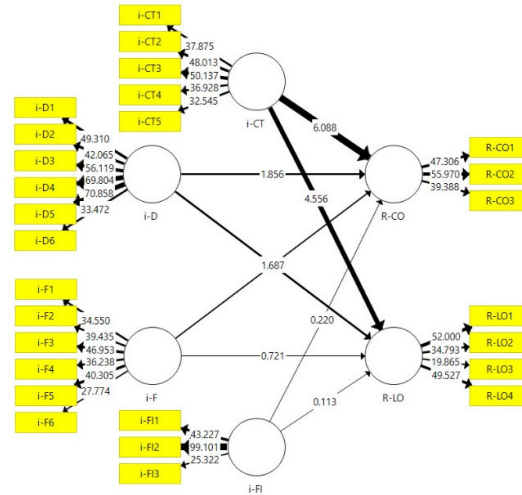

Fig. 3. Modeling i-deals in human talent retention

4.2. Assessment of the Structural Model

After verifying the validity and reliability of the measurement model, the relationships of the constructs were tested. The hypotheses were tested by examining the road coefficients and their levels of significance. Bootstrapping was performed with 5000 subsamples to verify the statistical significance of each of the road coefficients (Rodríguez-Giraldez & Vicente-Ramos, 2020). Fig. 3 shows the estimated trajectory of the PLS analysis. Table 2 shows that 2 of the 7 specific relationships have p < 0.05 (H1, H2 and H4 are accepted); while hypotheses H3, H5, H6, H7 and H8 are denied.

Table 2

Results of the model structure analysis

Hypotheses	Mean sample	Standard deviation	Beta	p value	Decision
i-CT → R-CO	0.452	0.074	6.088	0.000	Accept H1
i-CT → R-LO	0.358	0.079	4.556	0.000	Accept H2
i-D → R-CO	0.159	0.086	1.856	0.064	Denied H3
i-D → R-LO	0.170	0.083	2.052	0.040	Accept H4
i-F → R-CO	-0.153	0.091	1.687	0.092	Denied H5
i-F → R-LO	-0.058	0.081	0.721	0.471	Denied H6
i-FI → R-CO	-0.017	0.075	0.220	0.826	Denied H7
i-FI → R-LO	-0.009	0.078	0.113	0.910	Denied H8

6. Discussion and conclusion

Regarding the influence of work content i-deals (i-CT) on the retention of human talent in the Health Networks of Satipo - Peru

The result was a high influence between the i-deals of work content (i-CT) and the retention of human talent, obtaining (0.904) according to Cronbach's alpha. It was possible to identify a positive influence on the i-deal criteria of work content and commitment to the organization (p < 0.05), therefore, the H1 is accepted. In the same way, it was possible to identify a positive influence on the i-deal criteria of work content and loyalty to the organization (p < 0.05), therefore, H2 is accepted.

According to the results obtained, a high correlation between the two variables can be reaffirmed, this coincides with what was indicated by Rousseau et al. (2016) who point out that the i-deals of work content make workers more loyal to the organization. Dabos and Rivero (2012) who, in a study of executives in Argentina, identified that one of the types of i-deals that were most practiced were those of work content, the same situation that occurred in another study carried out by the same authors, this time aimed at scientists with research and development tasks. On the other hand, Hornung et al. (2009) differed in their research of German supervisors, as they found that i-deals of work content had not positively impacted employees' standards of performance, motivation, or work-life balance.

In short, it can be deduced that in the Health Networks, Work Content techniques are being used, where each employee performs in each service according to their technical and soft skills, thus allowing workers to develop according to their personal interests. Over the years, an optimal and effective change is being made in the way and retention of human talent, which is allowing organizations and entities to gain more loyal workers by giving them tasks that fit their skills that are personally motivating based on mutual commitment and job stability.

Regarding the influence of development i-deals (i-D) on the retention of human talent in Peru's Satipo health network

The result was a high influence between development i-deals (i-D) and the retention of human talent, obtaining (0.940) according to Cronbach's alpha. It was possible to identify an almost significant influence on the criteria of i-deals of development and commitment to the organization, because the results revealed the value of p value as 0.064 which indicates a minimum difference of 0.05 ($p > 0.05$), it is concluded that the influence of the i-deals of development and commitment in the organization does not exert such a marked impact on the entity, hence, H3 is discarded. In the same way, it was possible to identify a significant influence on the i-deal criteria of development and loyalty with the organization ($p < 0.05$), therefore, H4 is accepted.

Thus, a high correlation between the two variables can be reaffirmed. This coincides with what was indicated by Hornung et al. (2009) who, in a study of German supervisors, identified that one of the most relevant i-deals was development, as it had a positive impact on the performance and motivation of workers. Similarly, Dabos and Rivero (2012) who, in a study of scientists with research and development tasks, revealed that they have career development i-deals for their assistants. On the other hand, Bal et al. (2012) in a study in the Netherlands of retired employees showed that despite the significance between the development i-deal and their motivation to continue working, it was not relevant enough.

Likewise, it is concluded that in the Satipo Health Networks an ideal Development I deals are offered to the care and administrative staff. This is evidenced by the constant management of the Health Networks in contribution with their superior bodies (Minsa, Regional Government, Diresa, etc.) providing them with training that allows them to perform their functions according to aptitudes and skills, this practice not only contributes to the retention of human talent, but also fosters loyalty to the Entity. In recent times, entities and organizations have implemented the i-deal method, thus improving the forms of contracting and work modalities, as they have pointed out (Rentería & Vesga, 2019; Rentería and Malvezzi, 2018).

Regarding the influence of flexibility i-deals (i-F) on the retention of human talent in the health network of Satipo de Peru

The result was a high influence between flexibility i-deals (i-F) and human talent retention, obtaining (0.923) according to Cronbach's alpha. It was not possible to identify a significant influence on the i-deal criteria of flexibility and commitment to the organization ($p > 0.05$), therefore, the H5 was rejected. Likewise, the influence of flexibility and loyalty i-deals do not generate a positive impact according to the results in the entity ($p > 0.05$), therefore, H6 is rejected.

In recent times, there has been a lack of labor flexibility on the part of State Entities towards their servants. Instead of providing a flexible work environment, many times these servers are forced to strictly adhere to the employer's policies and rules. This lack of flexibility is minimal for state workers, even more so being in the health sector. Therefore, when conducting surveys in Satipo's Health Networks to assess the influence of idiosyncratic flexibility agreements on the retention of human talent, the results are unfavorable. This situation is aggravated in the health sector, as the health and well-being of the population is a priority. As a result, workers are often left dissatisfied, with little commitment or loyalty to the level of flexibility offered in their workplace.

However, Hornung et al. (2009), in their study of German supervisors, found that flexibility i-deals are important because of the positive impact on the employee's work-life balance rather than on their performance or motivation. On the other hand, Bal et al. (2012) in their study of retired employees in the Netherlands, found that flexibility i-deals are positively related to motivation to continue working. On the other hand, Dabos and Rivero (2012), in their study of executives in Argentina, identified that one of the types of i-deals that were most practiced were those of flexibility, the same situation that was identified in another study carried out by the same authors aimed at employees in the software and computer services sector.

Therefore, Entities and Organizations are strategic in attracting and negotiating through Flexibility i-deals in order to maintain competitiveness with precious talent in view of the fact that thanks to them organizations or entities meet their objective (Dabos & Rivero, 2012).

Regarding the influence of financial i-deals (i-FI) on the retention of human talent in Peru's Satipo Health Networks

The result was a high influence between financial i-deals (i-FI) and the retention of human talent, obtaining (0.876) according to cronbach's alpha. It was not possible to identify a significant influence on the criteria of financial i-deals and commitment

to the organization ($p > 0.05$), therefore, H5 was rejected. Likewise, the influence of financial i-deals and loyalty do not generate a positive impact according to the results on the entity ($p > 0.05$), therefore, H6 is rejected.

Nowadays, entities and organizations are in constant competition and challenge, where human resources management presents a great challenge to attract human talent. In this situation, entities aim to create new differentiated, personalized and salary recruitment strategies to attract candidates with skills and experience to meet institutional objectives.

According to a study on the role of personal resources, it has been determined that employees who do not have family responsibilities tend to negotiate and agree to more financial and flexibility agreements, such as overtime. This leads to the generation of an additional economic perception, which can be granted in the form of bonuses, gratuities, or other similar benefits. This approach suggests that employees without family responsibilities come to have an advantage in labor negotiations, since their availability for additional commitments can be positively valued by the organization (Rosen et al., 2020).

According to the results of the surveys applied, the servers indicate that financial incentives do not influence the retention of human talent in Satipo's Health Networks. This is because, in most cases, remuneration is not aligned with the required professional competencies. In addition, since it is a public entity, since by regulation workers who are under the CAS labor regime of D.L 1057 are not entitled to bonuses for overtime, designation of chiefs, among other benefits. This situation differs with the personnel under the labor regime Named 276 of D.L 1153, since they are entitled to certain additional bonuses. This leads to a lack of motivation at work among most workers. Mostly, organizations manage a variety of financial and non-financial resources for workers as compensation for effective performance in the workplace (Dabos & Rivero, 2012).

After the results of this research, it is concluded that in the Satipo Health Networks there is a considerable influence with the i-deals of work and development content. This is because workers are constantly trained and developed for their personal and professional interests, and they also perform according to their specializations, abilities, and skills. However, it is important to mention that innovative strategies must still be implemented in order to strengthen the Work and Development Content since in the Public Sector - Health the organizational culture, flexibility and financial aspect are quite limited and many times workers have to abide by it. These aspects need to be addressed in order to optimize the retention of Human Talent and improve their job satisfaction in the environment of Satipo's Health Networks.

The success of the employer's agreement and i-deals depends not only on the worker's optimal skills, but also on the employer's innovative offerings. In this context, the work environment and the direct relationship with the immediate boss play a very important role, since good relationships and job identification often generate motivation, commitment and loyalty to the Entity (Simosi et al., 2021).

Finally, after the elaboration of this research as well as previous examinations, it was possible to show that what Rousseau et al. (2006) proposed is true, which states that among the most practiced i-deals are those of development, flexibility and work content; Regardless of the type of workers surveyed and the context in which the research was conducted, some of these types of idiosyncratic contracts were negotiated to a greater or lesser extent, but their level of relevance will depend on each particular context. It is also worth mentioning the findings of Máñez et. Al (2017) who affirms the importance of compliance with i-deals, since, otherwise, it can emotionally exhaust the worker. Finally, according to Bal et al. (2012), in addition to compliance with i-deals, it is important to highlight the fundamental nature of the work environment to make it more appropriate and thus ensure that workers are willing to continue in the organization for longer.

References

- Bal, M., & Lub, X. D. (2018). Individualization of work arrangements. *Current Issues in Work and Organizational Psychology* (pp. 153–164).
- Bal, P. M., De Jong, S. B., Jansen, P. G. W., & Bakker, A. B. (2012). Motivating employees to work beyond retirement: A multi-level study of the role of I-deals and unit climate: I-deals and continuing working. *The Journal of Management Studies*, 49(2), 306–331.
- Benko, C., & Weisberg, A. (2007). *Mass career customization: Aligning the workplace with today's nontraditional workforce*. Harvard Business School Press.
- Bernal, C. A. (2010). *Metodología de la investigación*. Pearson
- Chiavenato, I. (2009). *Gestión del talento humano*. McGraw Hill.
- Dabos, G. E., & Rivero, A. G. (2012). Contratos idiosincrásicos en la atracción y retención del talento: tres estudios en organizaciones intensivas en conocimiento de la Argentina. *Estudios gerenciales*, 28(125), 3–12.
- Gómez, M. C. P., Santofimio, A. M., & Segura, V. (2007). El compromiso laboral: discursos en la organización. *Psicología desde el Caribe*, 19, 81-109.
- Greenberg, J., Roberge, M-E., Ho, V-T., & Rousseau, D. M. (2004). Fairness in idiosyncratic work arrangements: Justice as an I-deal. En J. J. Martocchio (Ed.), *Research in personnel and human resources management* (Vol. 23, pp. 1-34). Elsevier Science.
- Hølge-Hazelton, B., Kjerholt, M., Rosted, E., Thestrup Hansen, S., Zacho Borre, L., & McCormack, B. (2021). Health

- professional frontline leaders' experiences during the COVID-19 pandemic: A cross-sectional study. *Journal of Healthcare Leadership, 13*, 7–18.
- Hornung, S., Rousseau, D. M., & Glaser, J. (2008). Creating flexible work arrangements through idiosyncratic deals. *The Journal of Applied Psychology, 93*(3), 655–664.
- Hornung, S., Rousseau, D. M., & Glaser, J. (2009). Why supervisors make idiosyncratic deals: antecedents and outcomes of i-deals from a managerial perspective. *Journal of Managerial Psychology, 24*(8), 738–764.
- Kang, M., & Sung, M. (2019). To leave or not to leave: the effects of perceptions of organizational justice on employee turnover intention via employee-organization relationship and employee job engagement. *Journal of Public Relations Research, 31*(5-6), 152-175.
- Lai, L., Rousseau, D. M., & Chang, K. T. (2009). Idiosyncratic Deals: Coworkers as Interested Third Parties. *Journal of Applied Psychology, 94*(2), 547-556.
- Lee, C., & Hui, C. (2011). Antecedents and consequences of idiosyncratic deals: A frame of resource exchange. *Frontiers of Business Research in China, 5*(3).
- Lozano Correa, L. J. (2007). El talento humano, una estrategia de éxito en las empresas culturales. *Revista Escuela de Administración de Negocios, 60*, 147–164.
- Máynez Guaderrama, A. I., Cavazos Arroyo, J., & Reyes Flores, G. (2017). Efecto de la violación del contrato psicológico y el agotamiento emocional sobre el cinismo del empleado. *Estudios gerenciales, 33*(143), 124–131.
- Miranda Hoyes, D. (2016). Motivación del talento humano: La clave del éxito de una empresa. *Revista Investigación y Negocios, 9*(13), 20–27.
- Orejuela, J. (2014). Psicología de las organizaciones y del trabajo: apuestas de investigación. *La Identidad de la Evaluación del Trabajo y las Clínicas del Trabajo, 163-189*.
- Rentería, E. & Malvezzi, S. (2018). Psicologías organizacionales y de los trabajos–pots. Preguntas desde las realidades actuales del mundo del trabajo en América Latina. *Psicología desde el Caribe*. DOI: 10.14482/psdc.35.158.77
- Rentería Pérez, E., & Vesga Rodríguez, J. J. (2019). Niveles de análisis de las relaciones de trabajo: ¿un marco para el estudio del contrato psicológico de trabajo? *Diversitas, 15*(1), 131-144
- Robbins, S., & Judge, R. (2009). *Comportamiento Organizacional*. Pearson educación. México.
- Rodríguez-Giraldez, W., & Vicente-Ramos, W. (2020). Cultural aspects that influence the associative work of agricultural production chains in the Mantaro Valley of Peru. *Management Science Letters, 10*(2020), 2425–2430.
- Rofcanin, Y., Las Heras, M., Jose Bosch, M., Stollberger, J., & Mayer, M. (2021). How do weekly obtained task i-deals improve work performance? The role of relational context and structural job resources. *European Journal of Work and Organizational Psychology, 30*(4), 555-565.
- Rosen, C. C., Slater, D. J., Chang, C.-H. (daisy), & Johnson, R. E. (2013). Let's make a deal: Development and validation of the ex post I-deals scale. *Journal of Management, 39*(3), 709–742.
- Rousseau, D. M. (2001). The idiosyncratic deal: flexibility versus fairness? *Organizational Dynamics, 29*(4), 260-273.
- Rousseau, D. M. (2005). *I-deals: Idiosyncratic Deals Employees Bargain for Themselves*. Routledge
- Rousseau, D. M., Ho, V. T., & Greenberg, J. (2006). I-deals: Idiosyncratic terms in employment relationships. *Academy of Management Review, 31*(4), 977–994.
- Rousseau, D. M., Tomprou, M., & Simosi, M. (2016). Negotiating flexible and fair idiosyncratic deals (i-deals). *Organizational dynamics, 45*(3), 185–196.
- Schoberer, D., Reiter, L., Thonhofer, N., & Hoedl, M. (2022). Occupational relationships and working duties of nursing management staff during the COVID-19 pandemic: A qualitative analysis of survey responses. *Journal of Advanced Nursing, 1-13*.
- Simosi, M., Rousseau, D. M., & Weingart, L. R. (2021). Opening the black box of I-deals negotiation: Integrating I-deals and negotiation research. *Group & Organization Management, 46*(2), 186–222.
- Tena, G. (2002). El contrato psicológico: relación laboral empresa-trabajador. *Acciones e investigaciones sociales, 15*, 85–107.
- Vallejo Chávez, L. M. (2016). Gestión del talento humano. La caracola editores. <http://cimogsys.esPOCH.edu.ec/direccion-publicaciones/public/docs/books/2019-09-17-222134-gesti%C3%B3n%20del%20talento%20humano-comprimido.pdf>
- Zhan, Y., Ma, S., Jian, X., Cao, Y., & Zhan, X. (2020). The current situation and influencing factors of job stress among frontline nurses assisting in Wuhan in fighting COVID-19. *Frontiers. Public Health, 8*, 579866.

