

# Uncertain Supply Chain Management

homepage: [www.GrowingScience.com/uscm](http://www.GrowingScience.com/uscm)

## Brand image and customer behavior in container food courts: The role of social media content and generational differences in Indonesia

Sabar Sutia<sup>a\*</sup> and Mochammad Fahlevi<sup>b</sup>

<sup>a</sup>Management Department, Kusuma Negara Business School, Jakarta, Indonesia

<sup>b</sup>Management Department, BINUS Online, Bina Nusantara University, Jakarta 11480, Indonesia

### ABSTRACT

#### Article history:

Received January 9, 2024  
Received in revised format  
February 18, 2024  
Accepted March 28 2024  
Available online  
March 28 2024

#### Keywords:

Social Media  
Advertising  
Promotion  
Brand Image  
Customer Behavior  
Container Food Court

This study examines the impact of Social Media Advertising Content (SMAC) and Social Media Sales Promotion Content (SMSPC) on Brand Image (BI) and customer behavior (CB) within the emergent context of container food courts in Indonesia. Focusing on Jakarta and Surabaya, which are cities at the forefront of culinary innovation, this study aims to uncover how digital marketing practices shape consumer perceptions and behaviors in this novel sector. The study employed rigorous methodology, including G\*Power for sample size determination and SmartPLS for data analysis, and engaged 292 participants through a carefully designed survey. The findings indicated significant relationships between SMAC and SMSPC on BI, and subsequently on CB, underscoring the critical role of social media content in enhancing BI and shaping CB. Additionally, this study examines the generational differences between Generation Y and Generation Z, offering insights into tailored marketing strategies that cater to their distinct preferences. This study enriches academic discourse on the impact of digital marketing in the food industry and provides practical recommendations for practitioners aiming to leverage social media to enhance BI and foster positive CB in container food courts. The insights gained from this study not only illuminate the dynamics of social media marketing in an Indonesian context but also suggest avenues for future research in an ever-evolving digital landscape.

© 2024 by the authors; licensee Growing Science, Canada.

### 1. Introduction

The increasing demand for convenient and diverse dining options in Indonesian businesses has led to the emergence of container food courts (Indriani, 2016; Wardhani, 2016), a novel dining concept that reuses shipping containers to house a variety of food vendors. This innovative model offers a diverse selection of culinary choices, blending convenience with variety, making it an attractive option for consumers seeking accessible and diverse meals (Coorey et al., 2018; Fahlevi et al., 2019). The appeal of these dining enclaves is not only in their diverse food offerings, but also in their unique atmosphere, which combines trendiness with adaptability to changing culinary trends and consumer preferences. Container food courts, strategically situated in business districts, cater to diverse demographics, and encompass office workers seeking efficient lunch options and social gatherings in search of an engaging dining experience. Their adaptable model facilitates the prompt introduction of new cuisine and dining concepts, thereby minimizing risks while exploiting the dynamic food industry landscape (Dökmeci & Yılmaz, 2012). This versatility, along with the courts' strategic locations, augments their growing popularity as both a convenient dining solution and social focal point (Opoku et al., 2024). The increasing preference for convenient and diverse dining experiences indicates a broader shift in customer behavior (CB) (Ingerson & Kim, 2016; Quan & Wang, 2004; Yuan et al., 2023), characterized by a growing taste for ready-made meals and open communal dining spaces (Calderón et al., 2018). Food courts housed in containers exemplify this trend, as they offer a wide array of culinary options

\* Corresponding author

E-mail address: [sabarsutia@gmail.com](mailto:sabarsutia@gmail.com) (S. Sutia)

ISSN 2291-6830 (Online) - ISSN 2291-6822 (Print)

© 2024 by the authors; licensee Growing Science, Canada.

doi: 10.5267/j.uscm.2024.3.024

in an engaging, open-air setting. Vendors in these courts have adapted their offerings to cater to this demand for quality, simplicity, and satisfaction, demonstrating a keen awareness of consumers' tastes and dietary trends. Scholarly discussions surrounding container food courts reveal their origins in the rise of food trucks (Carpenter II & Sweetland, 2023) and pop-up markets (Rosenbaum et al., 2021), reflecting a consumer shift towards informal and varied dining experiences. The strategic selection of locations and vendors is critical for the success of these ventures, underscoring the significance of adaptability and quality in attracting loyal customers.

The digital era has significantly enhanced the reach and popularity of container food courts through social media, enabling them to establish a strong online presence. Online engagement, which includes promotional initiatives and event promotions, highlights the mutually beneficial relationship between container food courts and social media in nurturing a sense of community, bolstering brand visibility, and coping with the competitive food industry landscape. According to a report by We Are Social (2022), the active usage of social media is increasing, as evidenced by the latest statistics. As of January 2022, Indonesia has boasted 191 million social media users, accounting for more than half of the country's 275 million population. These data represent a significant increase from the previous year, with 170 million users representing a growth of 12.35%. Container food courts, known for their dynamic nature and constantly changing locations, require a strategic approach to location selection and promotion, particularly in the current digital age. Social media have emerged as a crucial tool in this context (Fahlevi, Syafira, et al., 2023; Marhaeni et al., 2022; Maskuroh et al., 2022), providing a dual advantage. First, it helps to inform potential customers about the court's current location, thereby increasing accessibility and visibility. Second, it enhances the venue's appeal through targeted marketing efforts, ultimately shaping CB and preferences. The influence of social media is supported by various studies. For instance, Nedra et al. (2019) highlight the impact of social media platforms on increasing customer buying interest. Similarly, Blasco-Lopez et al. (2019) emphasized the versatility of social media in providing users with comprehensive information swiftly, including locating businesses, accessing promotions, and obtaining contact details. In the context of container food courts, this means leveraging social media not only for broad promotional strategies, but also for conveying specific, timely information about their whereabouts and offerings. Moreover, Sarita and Suleman (2017) discussed the broader psychological benefits of platforms such as Instagram, which not only serve recreational purposes but also meet more fundamental needs by influencing decision-making processes, including the choice of dining locations and the enhancement of purchasing desires. Thus, social media serves as a bridge connecting the mobile nature of container food courts with consumers' static desire for novel, convenient dining experiences, ensuring that despite their ever-changing locations, these courts remain accessible and top-of-mind for potential patrons.

Kotler and Armstrong (2018) found that a product's visibility can stimulate CB, resulting in a desire for purchase and ownership. In the fast-paced environment of a container food court, this stimulation is amplified by the visual and interactive nature of the social media platforms. The presentation of culinary offerings on these platforms can directly influence consumer desire and decision-making. Positive brand image (BI) is crucial in this process (Matroji et al., 2023; Raji et al., 2019; Sutia et al., 2023). A distinctive and appealing online brand can drive CB and its responses significantly. Lee and Govindan (2014) further emphasize the need for companies to invest in enhancing their BI, as it has the power to shape customer perceptions and motivate purchase intentions. For container food courts, this involves leveraging social media to showcase their brand's uniqueness, quality, and diversity of culinary experiences. Engaging in content and interactive social media campaigns can foster a strong BI that resonates with their audience, encouraging not only one-time visits but also fostering a loyal customer base.

Sutia et al. (2023) and Salmiah et al. (2024) emphasized the significant impact of social media on CB. These authors state the importance of platforms such as Instagram as crucial channels for businesses to enhance their BI and stimulate purchasing interests. Bhaskoro (2013) showed a notable increase in business income following the adoption of Instagram for marketing purposes. This evidence underscores the strategic use of social media, including Instagram, by container food courts not only to inform and attract customers, but also to establish a powerful BI that drives CB and differentiates them in the competitive food industry landscape. Through effective communication of their unique value proposition, cultivation of positive BI, and attraction to a wider audience, container food courts can ensure their ongoing relevance and success in the fast-paced food industry.

The emergence of container food courts as a resilient and adaptable phenomenon in the food industry during the pandemic is noteworthy case for study (Shahbaz et al., 2020). Their capacity to not only survive but also prosper and expand in the face of such adversity underscores the importance of examining the factors contributing to their success. This resilience is further emphasized by their active engagement on social media platforms, a role that appears to be crucial in molding their BI and swaying CB (Gerritsen et al., 2021; Lahath et al., 2021). Despite the widespread use of social media by container food courts and their perceived success, there is limited empirical research examining the specific aspects of social media content, such as advertising and sales promotion, and their direct and indirect effects on CB in Indonesia's unique market. This study aims to fill this gap by investigating the influence of social media advertising content (SMAC) and social media sales promotion content (SMSPC) on CB, with a particular focus on the mediating role of BI and the moderating effect of age among Indonesian consumers. Although prior research has explored the impact of social media on brand perception and CB in general, this study seeks to differentiate between the types of content advertising and sales promotions, and how these different content forms contribute to shaping BI and ultimately affect CB in the context of container food courts. Additionally, the

demographic variable of age may play a critical moderating role given the varying social media consumption patterns across different age groups, an aspect that has not been adequately explored in this particular context.

The uniqueness of this study is underscored by its detailed exploration of the effects that distinct types of social media content have on CB towards container food courts in Indonesia, considering the mediating influence of BI and the crucial moderating impact of generational differences. By employing a multigroup analysis, this study aims to unveil the nuanced ways in which age groups, particularly Generation Y and Generation Z, respond differently to social media marketing efforts. This methodological approach enables a deeper understanding of the strategic importance of customizing content on social media platforms. This finding provides valuable insights for container food courts to refine their digital marketing strategies. By doing so, they can connect more efficiently with and engage their intended demographics, thereby promoting positive consumer actions and strengthening brand loyalty within a diverse and constantly changing marketplace.

Section 2 delves into foundational theory, focusing on the theory of planned behavior (TPB) and the variables within the model, as well as exploring the characteristics of different generations. Section 3 details the research procedures and design and provides a comprehensive overview of the methodological approach. Section 4 presents the statistical findings and discusses their implications for this study. Finally, Section 5 concludes the paper by summarizing the findings of the study, exploring the implications of the research, and acknowledging its limitations. This structure ensures a logical flow from a theoretical foundation through methodology to results, culminating in reflection on the study's broader impacts and constraints.

## 2. Literature Review

### 2.1 Theory of Planned Behavior (TPB)

The theory of planned behaviour (TPB) (Ajzen, 1991) is useful for exploring the intricate relationship between CB (Chou et al., 2020; Liao et al., 2007) and the impact of social media (Hansen et al., 2018) on BI (Lu & Chen, 2017), particularly in the context of container food courts. According to this theory, an individual's behavior is determined by their attitude, the social norms they perceive, and their sense of control over that behavior (Awa et al., 2015; Duan & Jiang, 2008). In the context of container food courts, social media has a significant influence on attitudes towards food, atmosphere, and overall experience. Positive portrayals of culinary variety and enjoyable dining experiences on social media can create a favorable perception among potential customers, leading to increased patronage and loyalty (Zhu et al., 2019). Social media also plays a critical role in shaping subjective norms by broadcasting endorsements from peers and influencers, which influences potential visitors' decision-making processes (Casaló et al., 2020; Fahlevi, Hasan, et al., 2023). Moreover, social media enhances perceived behavioral control by providing accessible information and facilitating interactions (Hansen et al., 2018), making it more attainable and appealing for potential customers to visit the food court. The application of TPB reveals that social media is not merely a promotional tool, but also a significant influencer of CB (Joo et al., 2020). It leverages attitudes, subjective norms, and perceived controls to drive visitation and engagement with container food courts. This insight underscores the importance of strategic social media use, not only in attracting customers, but also in cultivating a positive BI that resonates with the intended audience.

### 2.2 Social Media Advertising Content (SMAC)

The use of social media has significantly enhanced the scope of interactions and engagement between brand owners and their customers (Raji et al., 2019). Social media has expanded the realm of brand promotion by presenting numerous channels through which diverse styles of brand-related information can be propagated to consumers. Content, which refers to the information available through media or electronic products, plays a crucial role in this process. According to Munoz-Leiva et al. (2012), when users find social networks easy to use, they believe that the content posted will be useful for their decision-making. The strategic deployment of SMAC is a pivotal element in enhancing BI (Cheung et al., 2019) and influencing CB (Sundararaj & Rejeesh, 2021; Wibowo et al., 2021) within the context of container food courts, which have gained popularity because of their convenience, diversity of culinary options, and vibrant dining atmosphere. This form of advertising, encompassing a mix of text, images, videos, and interactive elements, is designed to capture the audience's attention and foster brand awareness, engagement, and ultimately conversion (Brajnik & Gabrielli, 2010; Mangold & Faulds, 2009). By creating content that is visually appealing, engaging, shareable, complete with compelling visuals, concise messaging, and clear calls to action, container food courts can effectively showcase their unique dining experiences, the array of food choices available, and highlight special promotions or events. Incorporating user-generated content such as customer reviews bolsters credibility and trust among potential patrons (Ahmad et al., 2023; Shestakofsky & Kelkar, 2020). Additionally, by tailoring and personalizing this content based on user demographics, interests, and behaviors, businesses can ensure that their advertising efforts reach the most receptive audience, significantly enhancing the likelihood of engagement and conversion (D. Lee et al., 2018). This approach not only introduces busy professionals to the convenience and variety offered by these food courts, but also cements the food courts' reputation as lively, social spaces, ultimately shaping customer attitudes, influencing their dining decisions, and encouraging loyalty and repeat visits, highlighting the indispensable role of strategic social media content in the success and appeal of container food courts in today's digitally driven marketplace.

### 2.3 Social Media Sales Promotion Content (SMSPC)

The significance of social media as a sales promotional platform has grown increasingly prominent (Mangold & Faulds, 2009; Tsimonis & Dimitriadis, 2014), merging the distribution of information with the strategic objective of shaping consumer attitudes and behaviors (Khamaludin et al., 2022). According to Buil et al. (2013), promotion involves communication between sellers and potential buyers to influence their perceptions and actions. In the digital world, social media has emerged as an adaptable channel for brand promotion, equipping marketers with a variety of tools for building brand identity, including paid advertising, brand persona engagement, and the creation and publication of branded content, often referred to as content marketing or social publishing (Tuten & Mintu-Wimsatt, 2018). The SMSPC encompasses various activities that transmit product-related information through these channels to enhance BI and spur sales (Kumar et al., 2016; Raji et al., 2019). As described by Raji et al. (2019) and other scholars, sales promotions are a potent form of marketing communication on social media that involves dissemination of promotional information designed to inspire CB. Research into the tactics used in social media promotion content reveals a wide array of strategies employed by brands to capture the attention of their audiences (Schwemmer & Ziewiecki, 2018). Keller et al. (2011) highlighted the importance of sales promotions, particularly those that offer price deals and incentives, in building brand equity.

### 2.4 Brand Image (BI)

BI is an intricate concept that encompasses the collective perceptions, attitudes, and behaviors of consumers towards a brand (Faircloth et al., 2001; Sutia et al., 2023). BI is a multifaceted concept that encompasses both tangible elements, such as packaging, and intangible factors, such as consumer beliefs, emotions, associations, and symbolic meanings. The importance of BI in fostering consumer acceptance and loyalty is widely acknowledged and extended to various business contexts, including container food courts (Biel, 1992; Fahlevi et al., 2019; Lu & Chen, 2017). In such settings, BI reflects not only the individual identities of the food vendors but also the collective appeal of the food court. The success of a container food court depends on public perception in which factors such as quality, ambiance, variety, and reputation play critical roles in shaping the overall BI. Strong and positive BI can enhance customer attraction, foster loyalty, and drive growth, highlighting the importance of operators in carefully managing and nurturing their BI (Cretu & Brodie, 2007; Elbedweihy et al., 2016).

### 2.5 Customer Behavior (CB)

The CB is a vital aspect to consider when operating a container food court. This refers to the actions, decisions, and patterns that consumers exhibit when interacting with a brand (Adila et al., 2020) or making purchase decisions (Sahir et al., 2021; Suleman et al., 2022). These actions are influenced by various factors, such as BI (Raji et al., 2019), promotional activities (Mangold & Faulds, 2009; Schwemmer & Ziewiecki, 2018), and perceived value (Gan & Wang, 2017). To ensure the success of a container food court, it is essential to analyze and understand customer preferences, tastes, and behaviors. Conducting market research and gathering data on customer preferences can help identify popular food trends, optimize menu offerings, and create a unique and enjoyable dining experience for customers (Martinez-Ruiz & Gómez-Cantó, 2016). By tailoring offerings and marketing efforts accordingly, the container food court can attract and retain customers, ultimately leading to success. Improving customer understanding can aid the container food court in devising tailored promotional initiatives that appeal to its intended audience (Buil et al., 2013). The container food court, situated in a business district, presents a one-of-a-kind and practical dining experience for working professionals and employees. By featuring an array of food vendors, the container food court provides an array of culinary offerings and menu choices to suit various palates and dietary requirements (Sahir et al., 2021). A container food court can potentially draw on a broader clientele by presenting a diverse array of choices. This approach enables the establishment to accommodate the distinctive tastes and preferences of its intended audience (Carpenter II & Sweetland, 2023). Given its site in business districts, the container food court is well positioned to cater to the fast-paced routines of professionals and workers who may have restricted time for meals. By providing swift and hassle-free meal alternatives, the container food court enables patrons to enjoy delectable and satisfying meals without compromising their flavor or quality.

### 2.6 Generation Y and Z Characteristics

The significant implications for the success and strategic direction of container food courts in urban business areas stem from the evolving CB dynamics within Generation Y (millennials) and Generation Z. These demographic cohorts exhibit distinct preferences and behaviors (Ketter, 2020), making it essential to develop a nuanced understanding of effective market engagement (Thach et al., 2020). Members of Generation Y (millennials), born between the early 1980s and the mid-1990s (Kapferer & Valette-Florence, 2022), represent the pursuit of experiential dining. This generation places a premium on unique, trendy, and diverse culinary experiences, with convenience and variety being key considerations in food choice (Fan et al., 2023; Kraus et al., 2022). Their inclination towards experiential value over material possessions underscores the shift towards dining environments that offer novel and engaging experiences. Therefore, container food courts looking to cater to this demographic must continually innovate and provide a diverse range of trendy culinary options that can fulfil millennials' desire for new and exciting experiences. This generation, known as Generation Z, was born between the late 1990s and the early 2010s and is the first cohort to grow in a digital world (Ayoobzadeh et al., 2024). As a result, they have integrated

technology into all aspects of their lives, including dining. This generation values innovation, interactivity, and sustainability, and is looking for dining experiences that align with their digital proficiency and ethical values (Orea-Giner & Fusté-Forné, 2023). They are particularly interested in tech-driven dining solutions, such as mobile ordering and social media interactions, and demand sustainable and ethically sourced food options. This unique market position sets Generation Z in addition to other generations. As Generation Z begins to assert its presence in the workforce, it is anticipated that its economic clout and distinctive inclinations will exert a considerable influence on the culinary realm. To maintain relevance, container food courts must embrace advanced and ethically sound business models that leverage technology. This paradigm shift necessitates a pliable strategy that emphasizes digital engagement and sustainability, aligned with the preferences and lifestyles of this demographic.

Recognizing the distinct yet complementary traits of Millennials and Generation Z is essential to the success of container food courts. To appeal to millennials, it is important to develop and promote unique, varied, and convenient dining experience. Meanwhile, Generation Z valued technology and ethical practices, making it imperative to incorporate them into the dining experience. Therefore, a successful strategy should incorporate a blended approach that merges innovative culinary offerings, digital engagement platforms, and sustainable practices to accommodate the distinct preferences of both age groups (Fan et al., 2023).

### 3. Research Framework

Based on the literature review, the research framework can be varied as follows (see Fig. 1):

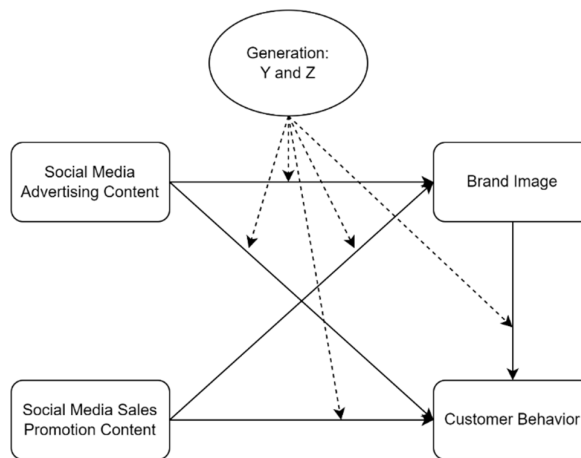

**Fig. 1.** Research Variables

This study focused on generational cohorts and conducted tests based on the characteristic traits of respondent generations to compare Generation Y and Generation Z, with a specific focus on CB within the context of container food courts in Indonesia.

### 4. Methodology

#### 4.1 Selection of Study Locations

The research methodology employed in this study was carefully devised to investigate the impact of social media on BI and CB in container food courts in Indonesia. Jakarta and Surabaya were chosen as the primary locations for investigation because of their distinguished status as pioneering cities for the container food court concept in Indonesia. These urban centers present a diverse and dynamic environment for examining emerging trends and CBs related to this innovative dining trend.

#### 4.2 Sample Size and Data Collection

G\*Power is an extensively used tool in power analysis that enables researchers to determine the minimum number of participants necessary to detect the effect of a specified magnitude with a desired level of significance (Kang, 2021). To achieve a balance between practicality and the need for a sufficient sample size to yield dependable and statistically significant outcomes, we employed G\*Power in our study. The calculation indicated that collecting data from 262 participants was sufficient to achieve our research objectives with an acceptable level of power. A rigorous filtering process was implemented to safeguard the integrity and quality of our dataset. This step was vital for ensuring that the collected responses were thoughtful and reflective of genuine engagement with the survey questions. Based on our preliminary research, we identified that respondents who completed the survey in less than 2 minutes were likely not to provide considered responses. This benchmark was established after observing that engaging with the survey's content, given its complexity and depth, typically

required more than 3 min. Therefore, responses completed in less than two minutes were excluded from the analysis to prevent the inclusion of hastily provided answers that could jeopardize the validity of our findings.

We thoroughly examined the dataset for consistency across all statements, which often signifies a lack of engagement or haphazard answering, potentially distorting research outcomes. We excluded responses that displayed a uniform pattern as they failed to demonstrate nuanced comprehension and deliberation, which the survey intended to capture. By eliminating these responses, we aimed to ensure that the final dataset comprised only insightful and well-considered inputs that accurately reflected the perspectives of the target population. After implementing these stringent quality control measures, 292 participants were included in the final sample. This refined sample represents a collection of valid and reliable responses that meet the criteria for meaningful analysis (Saunders et al., 2009; Sekaran & Bougie, 2016). This study succeeded in collecting 336 respondents and after the final data filtering process, the sample used in the study became 292, while preserving the validity of the data, emphasises the significance of achieving an equilibrium between quantity and quality, which is a critical factor in conducting research that aims to produce significant and practical outcomes (Lind et al., 2018).

#### *4.3 Survey Instrument and Sampling Technique*

The decision to use a 7-point Likert scale in the survey instrument was intentional, with the aim of accurately capturing participants' refined reactions towards statements concerning social media's effect on BI and CB (Saunders et al., 2009). This scale provides a comprehensive analysis by presenting a range of response options, from completely disagree to completely agree, thus enabling participants to express their opinions with greater accuracy. This precise approach is particularly valuable in research domains such as marketing and CB, because subtle differences in perception can significantly impact the study's findings (Dawes, 2008). The decision to employ a random sampling technique for participant selection from the pool of followers of container food courts' social media accounts was based on several crucial factors. Random sampling is a fundamental method for obtaining a representative sample of a larger population (Sekaran & Bougie, 2016), in which case the social media audience of container food courts. By randomly selecting participants, the study aimed to minimize selection bias, ensuring that the sample accurately reflected the broader population's characteristics and behaviors (Kadilar & Cingi, 2005). Furthermore, focusing on the followers of the food courts' social media accounts ensured that the sample consisted of individuals with a pre-existing interest in or engagement with the brand. This aspect is critical for two main reasons: it enhances the relevance of the research to actual and potential customers, and it provides insights into the behaviors and perceptions of a group already exposed to brands' social media marketing efforts. Such a sample is more likely to yield meaningful data on how social media content influences BI and CB, as these individuals have firsthand experience with the content in statement. Random sampling from this engaged audience pool allows for a diverse collection of insights, encompassing a wide range of opinions, experiences, and demographic backgrounds (Kadilar & Cingi, 2005). This diversity is essential for understanding the various ways in which different segments of the audience perceive and react to social media marketing, ultimately offering a comprehensive view of its effectiveness. By obtaining a broad spectrum of perspectives, this study aims to uncover patterns and trends that may not be apparent from a more homogenous or non-randomly selected sample (Saunders et al., 2009), thus providing a solid foundation for analyzing the impact of social media on CB within the context of container food courts.

#### *4.4 Questionnaire Development and Preliminary Research*

To enhance the precision and relevance of the questionnaire, extensive preliminary research was conducted (Alharbi et al., 2022; Noviantoro et al., 2020), our research on the impact of social media on BI and CB in container food courts benefited greatly from the crucial role played by the survey items, which were fine-tuned to accurately measure the variables of interest. Feedback from experts in the fields of marketing and culinary arts was sought to rigorously evaluate the questionnaire items. This process involved two anonymous reviewers who provided invaluable insights that were crucial in the selection and modification of the items to be included in or excluded from the final survey instrument. Their feedback was instrumental in aligning the questionnaire with the latest trends and practices in the fields of marketing and culinary arts, thereby ensuring that the survey accurately captured the nuances of social media's role in shaping consumer perceptions and behaviors.

The questionnaire was designed considering several key variables, each of which was derived from seminal and contemporary studies to provide a robust theoretical foundation for the survey. For the measurement of the SMAC, the items were adapted from Raji et al. (2019), Bronner and Neijens (2006) and Buil et al. (2013) comprehensively covered the various facets of the influence of advertising content through social media. Similarly, items related to content on social media sales promotion were sourced from Raji et al. (2019), Keller (2011), and Buil et al. (2013) reflect the broad spectrum of strategies employed in sales promotions via social platforms.

The development of the BI concept was influenced by the works of Villarejo Ramos (2002) and Rastogi et al. (2024), who enabled a detailed examination of the ways in which social media affects consumer perceptions of brands. The investigation of CB, a critical element of our study, was informed by a diverse array of sources including Quan and Wang (2004), Van der Heijden (2004), and Daries et al. (2024). This extensive approach enabled the questionnaire to capture various aspects of CB effectively in response to social media marketing initiatives. The development of the questionnaire was a meticulous process

underpinned by a strong theoretical foundation and expert validation, with the aim of yielding accurate and relevant data for our study. By integrating insights from authoritative sources and making adjustments based on expert feedback, the final questionnaire was designed to effectively capture the intricate relationship between social media and its impact on BI and CB in the ever-changing environment of container food courts.

#### 4.5 Data Analysis

The strategic selection of SmartPLS version 4 is of the utmost importance because of its advanced bootstrap multigroup analysis capability (Hair et al., 2017; Ringle et al., 2020; Sarstedt et al., 2017). This feature is particularly adept at dissecting complex model structures and quantifying variations between distinct demographic groups, making it an optimal tool for the objectives of our study. The primary goal of employing this advanced analytical approach was to scrutinize the interactions of Generation Y and Z with container food court brands on social media, where nuanced differences in behavior and preferences are both subtle and significant. SmartPLS's multigroup analysis facilitated an in-depth exploration of these generational segments, allowing us to conduct a detailed comparison of path coefficients and uncover the unique ways in which these cohorts engage with and perceive social media marketing efforts (Cheah et al., 2023). This methodology proved indispensable for revealing the distinct preferences, behaviors, and responses of Generation Y and Generation Z towards social media advertising and sales promotions. By enabling a granular analysis of how each group interacts with container food court brands on social media, SmartPLS provides the necessary insights to understand the intricate dynamics at play. The insights gained from this analysis are crucial for crafting digital marketing strategies that resonate with the specific characteristics and expectations of each generation. Through the application of SmartPLS version 4, our research not only identified the differential impacts of social media content on BI and CB but also highlighted the importance of tailoring marketing strategies to the evolving preferences of consumers within the vibrant and rapidly changing food court sector.

### 5. Results and Discussion

#### 5.1 Respondent Profile

The demographic makeup of the respondents is a crucial element in comprehending the context of CB in container food courts. This is demonstrated in Table 1, which presents a detailed breakdown of the demographic characteristics of the study participants, including gender, age, location, educational background, occupation, and monthly income. The distribution of these variables sheds light on the diversity of the customer base in Jakarta and Surabaya, which can affect their preferences and behaviors.

**Table 1**  
Respondent Demographics

Demographics	Category	Frequency	Percentage
Gender	Man	101	34.5%
	Woman	191	65.5%
Age	Y generation	169	57.88%
	Z generation	123	42.12%
Location	Jakarta	184	63%
	Surabaya	108	37%
Education Background	High School	137	46.9%
	Associate	34	11.5%
	Bachelor	111	38.1%
	Master	10	3.5%
Occupation	Student	111	38.1%
	Government employees	13	4.4%
	Private employees	119	40.7%
	Businessman	28	9.7%
	Other	21	7.1%
Income per month	< IDR 3.000.000	153	52.5%
	IDR 3.000.000 - IDR 5.000.000	57	19.5%
	IDR 5.000.000 - IDR 10.000.000	60	20.4%
	> IDR 10.000.000	22	7.6%

Table 1 presents the demographic characteristics of the 292 respondents who participated in the study, revealing a predominance of female participants and substantial representation of Generation Y. The majority of respondents were from Jakarta, reflecting the city's status as a prominent center for container food courts. The educational background of the participants was generally diverse, encompassing a wide range of educational experiences, from high school graduates to bachelor's degree holders. A considerable proportion of the respondents were students or private employees, consistent with the target demographics of container food courts. In terms of income, more than half of the respondents earned less than IDR 3,000,000 per month, indicating that container food courts are a popular choice among individuals from various economic backgrounds. It is essential for container food courts to understand these demographic factors to develop effective marketing strategies and culinary offerings that cater to the unique needs and preferences of diverse customer bases.

### 5.2 Descriptive Statistics

Descriptive statistics offer a quantitative summary of the data collected from the survey respondents and provide valuable insights into the central tendencies and dispersion of responses to the items in the questionnaire. Table 2 displays the mean, median, standard deviation, excess kurtosis, and skewness for each item related to SMAC, SMSPC, BI, and CB. These statistics are essential for interpreting the data and identifying patterns and anomalies within responses. They also serve as an initial step towards deeper analytical processes such as hypothesis testing or regression analysis.

**Table 2**  
Descriptive Statistics

Items	Mean	Median	Standard deviation	Excess kurtosis	Skewness
SMAC1	5.144	5.000	1.355	-0.119	-0.637
SMAC2	5.469	6.000	1.229	0.229	-0.786
SMAC3	5.312	5.000	1.197	0.321	-0.620
SMAC4	5.325	5.000	1.165	0.419	-0.553
SMAC5	5.507	6.000	1.093	-0.594	-0.286
SMAC6	5.784	6.000	1.193	0.030	-0.842
SMSPC1	5.466	6.000	1.186	-0.636	-0.432
SMSPC2	5.692	6.000	1.041	-0.135	-0.510
SMSPC3	5.634	6.000	1.094	0.948	-0.793
SMSPC4	5.589	6.000	1.090	-0.002	-0.581
SMSPC5	5.551	6.000	1.144	0.946	-0.727
SMSPC6	5.682	6.000	1.149	0.430	-0.825
SMSPC7	5.955	6.000	1.132	0.712	-1.064
BI1	5.565	6.000	1.187	-0.531	-0.513
BI2	5.568	6.000	1.110	1.155	-0.793
BI3	5.332	5.000	1.209	0.614	-0.719
BI4	5.192	5.000	1.289	0.306	-0.555
BI5	5.329	6.000	1.231	0.525	-0.791
BI6	5.510	6.000	1.061	0.844	-0.683
CB1	5.435	6.000	1.119	0.196	-0.551
CB2	5.065	5.000	1.290	-0.055	-0.478
CB3	5.212	5.000	1.206	0.564	-0.697
CB4	5.421	6.000	1.187	0.446	-0.640
CB5	5.212	5.000	1.376	0.715	-0.831

The descriptive statistics presented in Table 2 offer valuable information regarding the distribution of responses to the survey items. The mean scores generally fell within the 5–6 range on a 7-point scale, indicating a positive reaction towards the container food court's social media content and BI. The median values closely align with the means, further suggesting central clustering of the data points. The standard deviation values, reflecting the variability in the responses, were relatively low across all items, indicating consensus among the respondents' perceptions. Items with lower skewness values are more symmetrically distributed around the mean, while those with higher skewness values indicate a deviation from a normal distribution; generally, kurtosis values tend to lean towards the higher end of the range in this context. The excess kurtosis values offer insights into the distribution of the data. When the values are closer to zero, the distribution is similar to the normal distribution, whereas positive values indicate a distribution that is more peaked than normal, and negative values suggest a flatter distribution than normal (Lind et al., 2018). In our case, most items showed a slight deviation from the normal distribution, which could be due to specific CBs or perceptions within the context of the container food court. Understanding these statistics is crucial for the container food court industry in Indonesia, as they reflect consumer attitudes and behaviors towards marketing efforts on social media and the overall BI. These insights can be utilized to tailor marketing strategies and improve customer experience to better meet the expectations of food court patrons.

### 5.3 Measurement Model

In the Measurement Model section of our study, we examined the dependability and legitimacy of the variables used to measure SMAC, SMSPC, BI, and CB within the context of container food courts. To achieve this objective, we employed the Partial Least Squares (PLS) algorithm, as depicted in Fig. 2. The PLS algorithm is a statistical method designed to optimize the explained variance of dependent variables by leveraging a set of independent variables (Ringle et al., 2020). This technique is especially beneficial for our research, as it enables the evaluation of the potency and significance of the associations between variables in the model.

The Outer Model was evaluated using the PLS Algorithm, as presented in Table 3. This evaluation is essential to ascertain the reliability and convergent validity of measurement scales. The Outer Model table provides the factor loadings, composite reliability (CR), Cronbach's alpha, and average variance extracted (AVE) for each item under the variables of interest. Factor loadings represent the individual items' correlation with their respective variables and values above 0.7 are typically considered acceptable (Sarstedt et al., 2017).



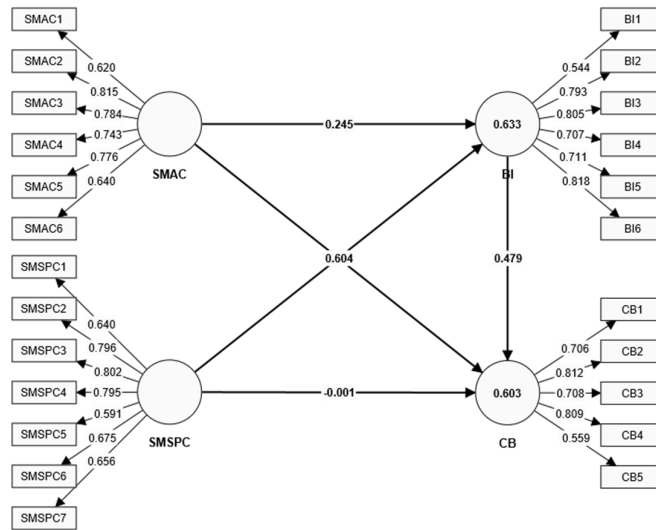

Fig. 2. PLS Algorithm

Table 3  
Outer Model

Variables	Item	Factor Loadings	CR	Cronbach Alpha	AVE	
Social Media Advertising Content (SMAC)	SMAC1	The advertisement on social media offered me something new regarding the container food court.	0.620	0.827	0.823	0.653
	SMAC2	The advertisement on social media provides useful information about the container food court.	0.815			
	SMAC3	The advertisements on social media provided me with credible information about the container food court.	0.784			
	SMAC4	The container food court's social media advertisements were designed creatively.	0.743			
	SMAC5	The advertisements on social media assisted me in forming an opinion about the container food court.	0.776			
	SMAC6	I am persuaded by the advertising campaigns for the container food court on social media.	0.640			
Social Media Sales Promotion Content (SMSPC)	SMSPC1	Price deals are frequently announced on social media by the container food court.	0.640	0.824	0.821	0.737
	SMSPC2	New dishes are announced on social media by the container food court.	0.796			
	SMSPC3	Themed events are announced on social media by the container food court.	0.802			
	SMSPC4	Gifts are offered on social media by the container food court.	0.795			
	SMSPC5	Discounts on food items or combo deals are offered on social media by the container food court.	0.591			
	SMSPC6	Coupons for discounts or special offers are provided on social media by the container food court.	0.675			
	SMSPC7	Exclusive dining experiences are given on social media by the container food court.	0.656			
Brand Image (BI)	BI1	The container food court has a strong personality	0.544	0.838	0.832	0.666
	BI2	The container food court has a powerful image	0.793			
	BI3	The container food court is recognized as a sustainable business with a positive image	0.805			
	BI4	The container food court has a good environmental reputation	0.707			
	BI5	The container food court is known for its innovative approach to food and dining experiences	0.711			
	BI6	The container food court offers a diverse and inclusive dining experience reflecting a wide range of cultures and tastes	0.818			
Customer Behaviour (CB)	CB1	I enjoy exploring new culinary experiences at the container food court	0.706	0.791	0.779	0.603
	CB2	I value learning about innovative food preparation, cooking techniques, and presentation at the container food court	0.812			
	CB3	I am satisfied with my experience at the container food court; it meets my expectations for variety and quality	0.708			
	CB4	I would recommend the container food court to my family and friends and share my positive experience on social networks	0.809			
	CB5	My positive experience at the container food court makes me eager to revisit and recommend it as a must-visit destination	0.559			

Table 3 provides an evaluation of the Outer Model analysis by examining the factor loading for each item. A factor loading above 0.7 indicates a strong relationship between the item and its corresponding variable, suggesting that the item is an effective measure of that variable. In this study, items with factor loadings below 0.7 are considered for removal to enhance the model's variable validity. For example, SMAC1 and SMAC6, with factor loadings of 0.620 and 0.640, respectively, are close to meeting the criteria and can be removed to enhance the SMAC variable. The dependability of the variables was affirmed through the employment of Cronbach's Alpha and Comparative Reliability (CR) scores, both of which are above the acceptable limit of 0.7, thereby signifying that the variables were accurately measured. The Aspect Value Equivalents (AVE) values surpass 0.5, attesting to the fact that the majority of the variance in the items is accounted for by the variables (Hair et al., 2019). However, it is suggested that items such as BI1 and CB5, with factor loadings of 0.544 and 0.559, respectively, be eliminated to improve the overall quality of the measurement model and ensure that each variable effectively represents the variable it is intended to measure. In the context of container food courts, the filtered items that remain in the model following this analysis accurately reflect consumers' interactions with the brand's social media content, their perception of the BI, and the resulting CB. The refined variables and items provide clearer insights into how consumers perceive and interact with container food courts through social media and how these perceptions influence their behavior.

The Heterotrait-Monotrait Ratio (HTMT) is a metric commonly used in variance-based structural equation modeling (SEM) methods, including PLS-SEM (Ringle et al., 2020), to evaluate discriminant validity. This refers to the extent to which a variable is differentiated from others based on empirical evidence, which is essential in ensuring that variables that are supposed to be unrelated are indeed statistically distinct. Table 4 provides the HTMT values to examine the discriminant validity of the variables BI, CB, SMAC, and SMSPC in the context of container food courts.

**Table 4**  
HTMT

	BI	CB	SMAC	SMSPC
BI				
CB	0.865			
SMAC	0.683	0.785		
SMSPC	0.895	0.800	0.760	

Table 4 presents the HTMT ratios for various variables. According to the HTMT criterion, a value below 0.90 indicates acceptable discriminant validity between variables, suggesting that they are empirically distinct. However, the high HTMT values observed between some variables, such as BI and SMSPC (0.895), necessitate reassessment of the items comprising these variables. Consequently, we determined that removing item BI5 from the BI variable is appropriate. This decision is based on the notion that BI5 may share too much content with items in the SMSPC variable, leading to an overlap in their measured aspects. The Fornell-Larcker criterion is commonly employed to evaluate discriminant validity (Hair et al., 2017). The Fornell-Larcker criterion requires that the square root of the AVE of each variable be greater than its highest correlation with any other variable, which involves comparing the square root of the AVE for each variable with its correlation.

**Table 5**  
Fornell-Lacker

	BI	CB	SMAC	SMSPC
BI	<b>0.816</b>			
CB	0.703	<b>0.776</b>		
SMAC	0.568	0.633	<b>0.808</b>	
SMSPC	0.746	0.648	0.625	<b>0.858</b>

Table 5 presents the findings of the Fornell-Larcker criterion, which provides additional evidence of discriminant validity among the variables assessed in our study. The diagonal entries in the table, highlighted in bold, signify the square root of the AVE for each variable, and these values should be larger than the off-diagonal entries in the corresponding rows and columns. These outcomes indicate that each variable shares a greater amount of variance with its indicators than with other variables, thereby demonstrating sufficient discriminant validity. Additionally, the decision to exclude BI5 is reinforced by these results, as it enhances the discriminant validity of the BI variable and ensures that each variable in our study captures a distinct aspect of consumer experience within the container food court setting.

#### 5.4 Model Fit

Model fit indices are crucial in SEM for assessing the extent to which the proposed model accurately represents data. These indices enable researchers to evaluate the consistency of the model structure with the observed data patterns (Hair et al., 2019). The Saturated model serves as a benchmark, representing a perfectly fitting model, where the estimated parameters correspond to the number of observed variances and covariances. In contrast, the estimated model, which typically imposes specific theoretical constraints, is tested. Table 6 presents various model fit indices, including the standardized root mean square residual (SRMR), discrepancy functions such as  $d_{\text{ULS}}$  (Unweighted Least Squares),  $d_{\text{G}}$ , Chi-square statistic, and Normed Fit Index (NFI). Collectively, these indices provide valuable insights into the adequacy of model fit (Ringle et al., 2020;

Sarstedt et al., 2017).

**Table 6**  
Model Fit

	Saturated model	Estimated model
SRMR	0.071	0.071
d_ ULS	0.613	0.613
d_ G	0.272	0.272
Chi-square	459.344	459.344
NFI	0.804	0.804

Table 6 presents the model fit indices for both the Saturated and Estimated models used in our study. Notably, the indices for the saturated and estimated models are identical, which suggests that our estimated model fits the data as well as a model that is perfectly designed for the data. The SRMR value of 0.071 was below the commonly accepted threshold of 0.08, indicating that the model provided a good fit to the observed data. In addition, the  $d_{ULS}$  and  $d_G$  values, which assess the disparity between the observed and predicted covariance matrices, further support the conclusion that the model fit is adequate. The Chi-square statistic, commonly regarded as sensitive to sample size, offers a direct examination of the disparity between the observed and estimated covariance matrices. A lower chi-square value relative to the degrees of freedom suggests a superior fit. However, in the context of SEM, the focus is frequently on relative fit indices, such as the NFI, which in our case stands at 0.804. Although NFI values closer to 1 indicate a better fit, values above 0.8 are typically considered indicative of an acceptable fit to the data. The congruence between the Saturated and Estimated model fit indices suggests that the theoretical constraints imposed by our estimated model do not significantly impede its ability to fit data. This outcome is encouraging because it implies that the theoretical model devised to represent CB and brand interaction in the context of container food courts in Indonesia is well supported by the collected data.

The results of the statistical analysis demonstrated that both SMAC and SMSPC have a significant impact on BI and CB in the context of Indonesian container food courts. R-squared values of 0.573 and 0.582 indicate that these variables explain a substantial proportion of the variance in the outcomes. This was further supported by the adjusted R-squared values, which were very close to the R-squared values, indicating that the model was robust. The F-square values indicate the effect sizes of each predictor on the outcomes, where SMSPC has a large effect size on BI (0.589) and minimal effect on CB (0.019), indicating its strong predictive power. In contrast, SMAC showed a small effect on BI (0.040) and a moderate effect on CB (0.129), suggesting that it is a more influential predictor of CB than BI. These findings suggest that sales promotions on social media are particularly effective in shaping BI, while advertising content is also a significant determinant of how customers behave towards these food courts.

### 5.5 Structural Model

The primary objective of the Structural Model section of our research was to examine the theoretical relationships between SMAC, SMSPC, BI, and CB. To gauge the strength and significance of these relationships, we employed a bootstrapping technique in PLS-SEM, which enables non-parametric resampling to approximate the accuracy of the path coefficients. Fig. 3 graphically represents the bootstrapping process, which is a crucial step in evaluating the reliability of path coefficients derived from our structural model. This method allows us to address the potential distributional assumptions of our sample and provides more robust estimates of standard errors and t-statistics for hypothesis testing (Lind et al., 2018).

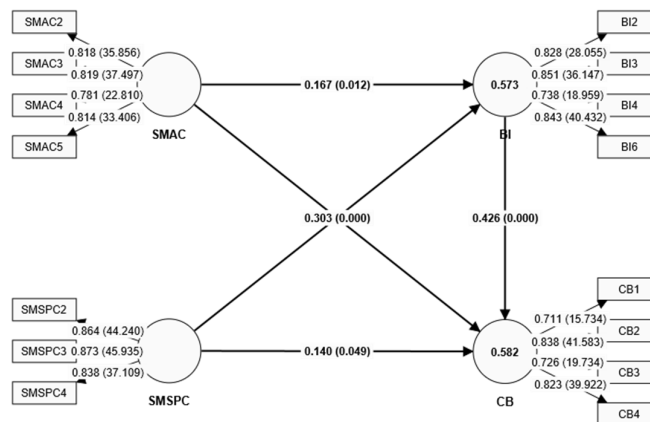

**Fig. 3.** Bootstrapping

Using the bootstrapping process outlined in Fig. 3, we evaluated the outcomes of the path analysis presented in Table 7. This table provides a comprehensive summary of the path coefficients between variables, encompassing the original sample

estimates, sample mean, standard deviation, t-statistics, p-values, and status of the hypotheses. By conducting path analysis, we were able to scrutinize the direct and indirect effects within our model, thereby assessing the proposed hypotheses pertaining to the influence of social media content on BI and subsequently on CB.

**Table 7**  
Path Analysis

Path	Original sample (O)	Sample mean (M)	Standard deviation (STDEV)	T statistics ( O/STDEV )	P values	Hypothesis
SMAC → BI	0.167	0.174	0.074	2.248	0.012	Accepted
SMSPC → BI	0.642	0.636	0.066	9.657	0.000	Accepted
SMAC → CB	0.303	0.300	0.065	4.698	0.000	Accepted
SMSPC → CB	0.140	0.140	0.084	1.660	0.049	Accepted
BI → CB	0.426	0.430	0.073	5.845	0.000	Accepted
SMAC → BI → CB	0.071	0.075	0.034	2.073	0.019	Accepted
SMSPC → BI → CB	0.274	0.274	0.057	4.792	0.000	Accepted

The findings from the path analysis presented in Table 7 reveal intricate connections between social media content, BI, and CB within the context of container food courts. The analysis demonstrates how SMAC has a positive impact on BI, with the path coefficient indicating that attention-grabbing and relevant advertising content on social media platforms can substantially improve BI among its target audience. This impact is statistically significant, as evidenced by the T statistics surpassing the critical value, which highlights the robustness of SMAC's effect on BI. Similarly, SMSPC displays a strong, positive influence on BI, suggesting that promotions shared on social media are highly effective in enhancing a brand's perceived value. This relationship is not only statistically significant, but also possesses one of the highest path coefficients, emphasizing the powerful role of sales promotions in shaping BI. The sway of SMAC extends to CB, implying that advertising content not only affects BI but also directly influences how customers interact with the brand, encouraging favorable behavior. This relationship is again supported by the significant T-statistics, indicating a dependable effect. Furthermore, the analysis reveals that the SMSPC has a positive but slightly weaker direct impact on CB than on BI. This suggests that while sales promotions on social media significantly enhance BI, their direct influence on CB is more moderate yet statistically significant. The relationship between BI and CB is particularly noteworthy and characterized by a strong path coefficient, indicating that a positive BI directly leads to a favorable CB. This relationship was statistically significant in the analysis, underscoring the central role of BI in influencing CB with the brand. The indirect effects of social media content on CB through BI were analyzed, showing that both forms of social media content not only have a direct impact on CB, but also an indirect impact through enhancing BI. These paths are statistically significant, illustrating the multifaceted role of social media content in shaping a brand's CB.

5.6 Multigroup Analysis

In our study, we expanded the analysis to investigate potential variations in the relationships between social media content, BI, and CB across different demographic groups. This was accomplished through the application of Multigroup Analysis, a statistical method that enables the comparison of path coefficients between predefined groups. In this study, the groups are determined by generational cohorts, specifically Generation Y and Generation Z. Fig. 4 depicts the Bootstrap Multigroup Analysis process, which entails bootstrapping within each group to evaluate the stability and significance of any differences in the path coefficients. This step is essential to comprehending whether and how generational distinctions affect the influence of social media marketing tactics on brand perception and customer actions within the context of container food courts.

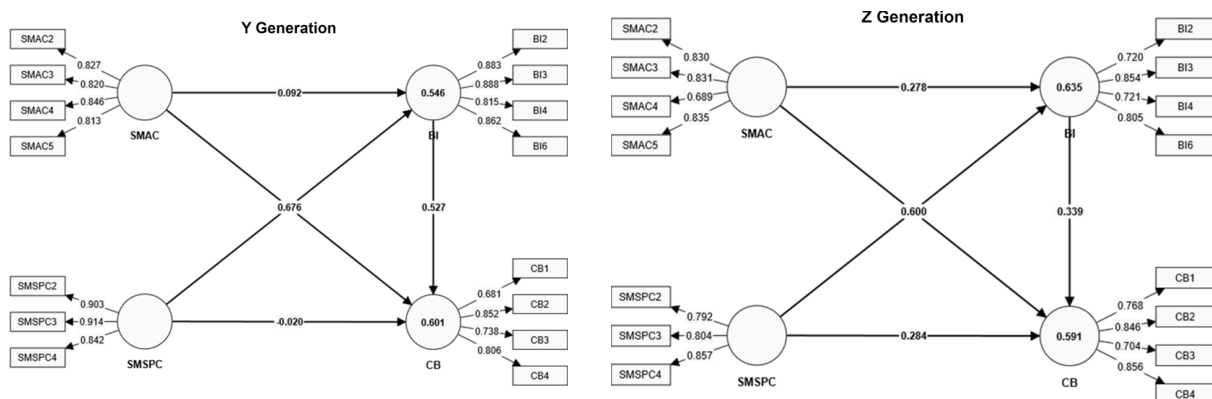

**Fig. 4.** Bootstrap Multigroup Analysis

As depicted in Fig. 4, the Bootstrap Multigroup Analysis provides the basis for our examination of specific generational influences, which is further explored in Table 8 through the Path Multigroup Analysis. This table compares the effects SMAC and SMSPC on BI and CB between Generation Y and Generation Z. The table includes the original and mean path coefficients, standard deviations, t-values, and p-values for each path within both generational cohorts, enabling a detailed understanding of the similarities and differences in how these generations interact and are influenced by social media content related to container food courts.

**Table 8**  
Path Multigroup Analysis

Path	Original (Y)	Original (Z)	Mean (Y)	Mean (Z)	STDEV (Y)	STDEV (Z)	t value (Y)	t value (Z)	p value (Y)	p value (Z)
SMAC → BI	0.092	0.278	0.113	0.273	0.106	0.098	0.873	2.833	0.191	0.002
SMSPC → BI	0.676	0.600	0.657	0.606	0.099	0.078	6.828	7.741	0.000	0.000
SMAC → CB	0.373	0.246	0.367	0.242	0.071	0.125	5.222	1.975	0.000	0.024
SMSPC → CB	-0.020	0.284	-0.016	0.287	0.105	0.134	0.189	2.114	0.425	0.017
BI → CB	0.527	0.339	0.531	0.340	0.089	0.144	5.946	2.360	0.000	0.009
SMAC → BI → CB	0.049	0.094	0.058	0.093	0.057	0.052	0.860	1.804	0.195	0.036
SMSPC → BI → CB	0.356	0.203	0.351	0.207	0.088	0.093	4.029	2.185	0.000	0.014

Table 8 presents a noteworthy contrast between generations Y and Z in their reactions to social media marketing strategies employed by container food courts. For instance, the progression from SMAC to BI demonstrates a more pronounced effect on Generation Z than Generation Y, implying that younger consumers might attach greater significance to the novelty and credibility of advertising content in shaping their perception of a brand. On the other hand, the influence of SMSPC on BI is significant for both generations, albeit slightly more pronounced for Generation Y, reflecting a universal appeal of sales promotions with generational variation in its intensity. Generation Y exhibited a stronger response to social media content on CB, whereas Generation Z appeared to be more influenced by SMSPC, especially when it came to sales promotions leading to positive brand behavior. It is intriguing to note that the negative coefficient for SMSPC to CB in Generation Y indicates potential saturation or skepticism towards sales promotions among this group, in contrast to Generation Z, which appears more receptive. The outcomes of this study emphasize the significance of devising social media marketing strategies that cater to the distinct preferences and behaviors of various generational cohorts. The multigroup analysis offers a comprehensive guide for container food courts to modify their social media content in a manner that appeals to both Generation Y and Generation Z, thereby enhancing BI and fostering favorable CB. Additionally, the indirect effects mediated by BI (BI → CB) and the combined paths (SMAC → BI → CB and SMSPC → BI → CB) highlight the crucial role of BI in translating social media content into CB. The differences in path coefficients between generations elucidate the nuanced ways in which BI mediates the connection between social media content and CB, with Generation Y displaying a stronger linkage, particularly through advertising.

## 6. Discussion

The significance of social media content in shaping BI and CB is emphasized, with notable distinctions observed between Gen Y and Gen Z. The positive impact of SMAC on BI is consistent with Lu and Chen (2017), who stressed the influence of social media on BI. Our findings support this assertion, emphasizing the potential of engaging advertising content on social media platforms to enhance BI among its target audience. Additionally, the strong positive effect of SMSPC on BI aligns with Raji et al. (2019), underscoring the efficacy of sales promotions shared on social media in boosting a brand's perceived value. This underscores the importance of strategic social media use not only to attract customers but also to foster a positive BI that resonates with the intended audience. The impact of SMAC and SMSPC on CB highlights the direct effect of social media content on shaping brand perception and influencing customer interactions with the brand. This aligns with the findings of Joo et al. (2020), who indicated that well-crafted advertising and sales promotion content on social media can lead to favorable CB towards container food courts. The strong correlation between BI and CB in the analysis underscores the pivotal role of BI in shaping CB with the brand, a finding that aligns with that of Sutia et al. (2023). This underscores the critical importance of maintaining a positive and attractive BI, as it directly influences favorable CB. Multivariate analysis, which investigates generational differences, indicates that Generation Z exhibits a more intense reaction to SMAC in terms of BI than Generation Y, suggesting that younger consumers place greater importance on the authenticity and originality of the advertising content. This result is consistent with Ayoobzadeh et al.'s (2024) description of Generation Z, which stressed their digital nativity and preference for innovation. However, the impact of the SMSPC on BI, although significant for both generations, suggests a nuanced approach to sales promotions, with Generation Y showing a slightly stronger response. This could be attributed to Generation Y's established economic power and responsiveness to direct promotional efforts, as proposed by Thach et al. (2020).

## 7. Implications

The ramifications of this research offer pertinent insights for both industry practitioners, particularly those involved in container food courts, and academics specializing in social media marketing dynamics. For practitioners, this study

emphasizes the essential role of devising strategic social media content that connects them with the intended audience. Engaging in visually appealing advertising and promotional content that accurately reflects a brand's identity and offerings can substantially enhance BI and positively impact CB. Container food courts are encouraged to customize their social media strategies to cater to the specific preferences and behaviors of various generational cohorts, particularly Generation Y and Generation Z, which exhibit distinct reactions to advertising and promotional content. This tailored approach can aid in attracting a wider customer base, fostering brand loyalty, and ultimately, driving sales.

This study advances the field of academic inquiry by examining the impact of social media on consumer perceptions and behaviors in the food industry. Specifically, the study sheds light on the complex ways in which social media content shapes BI and CB and delves into the underlying mechanisms that drive these effects. Moreover, by investigating the distinct influence of social media marketing across generations, this study paves the way for additional research on the evolving dynamics of digital marketing and CB. This opens new avenues for exploring the specific types of social media content that are most effective in engaging diverse demographic segments, ultimately contributing to the refinement of marketing strategies in the digital era.

## 8. Conclusions

This study sheds light on the considerable impact of SMAC and SMSPC on BI and CB in the context of container food courts. The results indicated that both forms of social media content significantly improved BI, which subsequently exerted a positive influence on CB. Furthermore, this study elucidates the nuanced reactions of different generational cohorts, particularly Generation Y and Generation Z, to social media marketing efforts. While both generational groups respond to SMAC and SMSPC, their reactions differ, emphasizing the necessity of tailored marketing strategies that accommodate the specific preferences and behaviors of these demographics. However, this study had several limitations. First, the research was geographically restricted, concentrating on container food courts in Indonesia, which may have limited the generalizability of the findings to other regions or food service models. Second, the study primarily employed quantitative methods and self-reported data, which may not fully capture the depth of consumers' perceptions and interactions with social media content. The dynamic nature of social media trends and consumer preferences poses a challenge to capturing the entire spectrum of influences on BI and CB. Future research could proceed in several directions. One possible avenue is to conduct comparative studies across various cultural and geographical contexts to determine the extent to which the effectiveness of social media marketing in the food industry is universally applicable or context specific. Another approach is to incorporate qualitative research methods, such as interviews or focus groups, to gain a deeper understanding of consumer perceptions and the motivations behind their responses to social media content. Future studies should explore the impact of emerging social media platforms and technologies on consumer engagement and marketing strategies. Investigating the long-term effects of social media marketing on brand loyalty and customer retention in the food court sector could provide valuable insights into sustainable business growth.

## References

- Adila, T. M., Bintang, W. S., Ikhsan, R. B., & Fahlevi, M. (2020). Instagram as information in developing purchase intentions: The role of social E-wom and brand attitude. *Proc. Int. Conf. Inf. Manag. Technol., ICIMTech*, 427–431. Scopus. <https://doi.org/10.1109/ICIMTech50083.2020.9211151>
- Ahmad, N., Ahmad, A., Lewandowska, A., & Han, H. (2023). From screen to service: How corporate social responsibility messages on social media shape hotel consumer advocacy. *Journal of Hospitality Marketing & Management*, 0(0), 1–30. <https://doi.org/10.1080/19368623.2023.2271448>
- Ajzen, I. (1991). The theory of planned behavior. *Organizational Behavior and Human Decision Processes*, 50(2), 179–211. [https://doi.org/10.1016/0749-5978\(91\)90020-T](https://doi.org/10.1016/0749-5978(91)90020-T)
- Alharbi, N. S., Alsubki, N., Altamimi, S. R., Alonazi, W., & Fahlevi, M. (2022). COVID-19 Mobile Apps in Saudi Arabia: Systematic Identification, Evaluation, and Features Assessment. *Frontiers in Public Health*, 10(803677), 1–6. <https://doi.org/10.3389/fpubh.2022.803677>
- Awa, H. O., Ojiabo, O. U., & Emecheta, B. C. (2015). Integrating TAM, TPB and TOE frameworks and expanding their characteristic variables for e-commerce adoption by SMEs. *Journal of Science & Technology Policy Management*, 6(1), 76–94. <https://doi.org/10.1108/JSTPM-04-2014-0012>
- Ayoobzadeh, M., Schweitzer, L., Lyons, S., & Ng, E. (2024). A tale of two generations: A time-lag study of career expectations. *Personnel Review*, ahead-of-print(ahead-of-print). <https://doi.org/10.1108/PR-02-2022-0101>
- Bhaskoro, A. T. (2013). *The Most Effective Social Media in Driving Business*. dailysocial.id. <https://dailysocial.id/post/laporan-akhir-tahun-sumall-instagram-sebagai-media-sosial-paling-efektif-dalam-memacu-bisnis>
- Biel, A. L. (1992). How brand image drives brand equity. *Journal of Advertising Research*, 32(6), 6–12.
- Blasco-Lopez, F., Recuero Virto, N., Aldas Manzano, J., & Cruz Delgado, D. (2019). Facebook's power: Factors influencing followers' visit intentions. *Spanish Journal of Marketing - ESIC*, 23(1), 95–117. <https://doi.org/10.1108/SJME-06-2018-0032>
- Brajnik, G., & Gabrielli, S. (2010). A Review of Online Advertising Effects on the User Experience. *International Journal of*

- Human-Computer Interaction*, 26(10), 971–997. <https://doi.org/10.1080/10447318.2010.502100>
- Bronner, F., & Neijens, P. (2006). Audience Experiences of Media Context and Embedded Advertising: A Comparison of Eight Media. *International Journal of Market Research*, 48(1), 81–100. <https://doi.org/10.1177/147078530604800106>
- Buil, I., de Chernatony, L., & Martínez, E. (2013). Examining the role of advertising and sales promotions in brand equity creation. *Journal of Business Research*, 66(1), 115–122. <https://doi.org/10.1016/j.jbusres.2011.07.030>
- Calderón, L. A., Herrero, M., Laca, A., & Díaz, M. (2018). Environmental impact of a traditional cooked dish at four different manufacturing scales: From ready meal industry and catering company to traditional restaurant and homemade. *The International Journal of Life Cycle Assessment*, 23(4), 811–823. <https://doi.org/10.1007/s11367-017-1326-7>
- Carpenter II, D. M., & Sweetland, K. (2023). Does the growth of food trucks threaten the sustainability of restaurants? Evidence from a nationwide analysis of U.S. businesses. *Journal of Foodservice Business Research*, 0(0), 1–22. <https://doi.org/10.1080/15378020.2023.2275514>
- Casaló, L. V., Flavián, C., & Ibáñez-Sánchez, S. (2020). Influencers on Instagram: Antecedents and consequences of opinion leadership. *Journal of Business Research*, 117, 510–519. <https://doi.org/10.1016/j.jbusres.2018.07.005>
- Cheah, J.-H., Amaro, S., & Roldán, J. L. (2023). Multigroup analysis of more than two groups in PLS-SEM: A review, illustration, and recommendations. *Journal of Business Research*, 156, 113539. <https://doi.org/10.1016/j.jbusres.2022.113539>
- Cheung, M. L., Pires, G. D., & Rosenberger, P. J. (2019). Developing a conceptual model for examining social media marketing effects on brand awareness and brand image. *International Journal of Economics and Business Research*, 17(3), 243–261. <https://doi.org/10.1504/IJEER.2019.098874>
- Chou, S.-F., Horng, J.-S., Sam Liu, C.-H., & Lin, J.-Y. (2020). Identifying the critical factors of customer behavior: An integration perspective of marketing strategy and components of attitudes. *Journal of Retailing and Consumer Services*, 55, 102113. <https://doi.org/10.1016/j.jretconser.2020.102113>
- Coorey, R., Ng, D. S. H., Jayamanne, V. S., Buys, E. M., Munyard, S., Mousley, C. J., Njage, P. M. K., & Dykes, G. A. (2018). The Impact of Cooling Rate on the Safety of Food Products as Affected by Food Containers. *Comprehensive Reviews in Food Science and Food Safety*, 17(4), 827–840. <https://doi.org/10.1111/1541-4337.12357>
- Cretu, A. E., & Brodie, R. J. (2007). The influence of brand image and company reputation where manufacturers market to small firms: A customer value perspective. *Industrial Marketing Management*, 36(2), 230–240. <https://doi.org/10.1016/j.indmarman.2005.08.013>
- Daries, N., Cristobal-Fransi, E., Sánchez-García, J., & Marine-Roig, E. (2024). Customers' behavioral intentions when visiting upscale restaurants: Enjoying the experience or posturing? *International Journal of Gastronomy and Food Science*, 35, 100840. <https://doi.org/10.1016/j.ijgfs.2023.100840>
- Dawes, J. (2008). Do Data Characteristics Change According to the Number of Scale Points Used? An Experiment Using 5-Point, 7-Point and 10-Point Scales. *International Journal of Market Research*, 50(1), 61–104. <https://doi.org/10.1177/147078530805000106>
- Dökmeci, P. N., & Yilmazer, S. (2012). Relationships between Measured Levels and Subjective Ratings: A Case Study of the Food-Court Area in CEPA Shopping Center, Ankara. *Building Acoustics*, 19(1), 57–73. <https://doi.org/10.1260/1351-010X.19.1.57>
- Duan, W., & Jiang, G. (2008). A review of the theory of planned behavior. *Advances in Psychological Science*, 16(02), 315.
- Elbedweihy, A. M., Jayawardhena, C., Elsharnouby, M. H., & Elsharnouby, T. H. (2016). Customer relationship building: The role of brand attractiveness and consumer-brand identification. *Journal of Business Research*, 69(8), 2901–2910. <https://doi.org/10.1016/j.jbusres.2015.12.059>
- Fahlevi, M., Hasan, F., & Islam, M. R. (2023). Exploring consumer attitudes and purchase intentions: Unraveling key influencers in China's green agricultural products market. *Corporate and Business Strategy Review*, 4(3), 74–87. <https://doi.org/10.22495/cbsrv4i3art8>
- Fahlevi, M., Syafira, A., Fidyanurhuda, K. I., & Nadia, N. (2023). The Influence of Social Media and EWOM on Generation Z's Trust and Purchase Intentions at Coffee Shops. *2023 8th International Conference on Business and Industrial Research (ICBIR)*, 489–494. <https://doi.org/10.1109/ICBIR57571.2023.10147633>
- Fahlevi, M., Zuhri, S., Parashakti, R., & Ekhsan, M. (2019). Leadership Styles of Food Truck Businesses. *Journal of Research in Business, Economics and Management*, 13(2), 2437–2442.
- Faircloth, J. B., Capella, L. M., & Alford, B. L. (2001). The Effect of Brand Attitude and Brand Image on Brand Equity. *Journal of Marketing Theory and Practice*, 9(3), 61–75. <https://doi.org/10.1080/10696679.2001.11501897>
- Fan, A., Shin, H. W., Shi, J., & Wu, L. (2023). Young people share, but do so differently: An empirical comparison of peer-to-peer accommodation consumption between millennials and generation Z. *Cornell Hospitality Quarterly*, 64(3), 322–337.
- Gan, C., & Wang, W. (2017). The influence of perceived value on purchase intention in social commerce context. *Internet Research*, 27(4), 772–785. <https://doi.org/10.1108/IntR-06-2016-0164>
- Gerritsen, S., Sing, F., Lin, K., Martino, F., Backholer, K., Culpin, A., & Mackay, S. (2021). The Timing, Nature and Extent of Social Media Marketing by Unhealthy Food and Drinks Brands During the COVID-19 Pandemic in New Zealand. *Frontiers in Nutrition*, 8. <https://www.frontiersin.org/articles/10.3389/fnut.2021.645349>
- Hair, J. F., Hult, G. T. M., Ringle, C. M., & Sarstedt, M. (2017). *A Primer on Partial Least Squares Structural Equation Modeling (PLS-SEM)* (2nd ed.). Sage.
- Hair, J. F., Risher, J. J., Sarstedt, M., & Ringle, C. M. (2019). When to use and how to report the results of PLS-SEM.

- Hansen, J. M., Saridakis, G., & Benson, V. (2018). Risk, trust, and the interaction of perceived ease of use and behavioral control in predicting consumers' use of social media for transactions. *Computers in Human Behavior, 80*, 197–206. <https://doi.org/10.1016/j.chb.2017.11.010>
- Indriani, R. (2016, February 9). Food Container Food Court Comes with a Unique Concept. *suara.com*. <https://www.suara.com/lifestyle/2016/02/09/065800/food-container-food-court-hadir-dengan-konsep-unik>
- Ingerson, S., & Kim, A. K. (2016). Exploring the value of an ethnic restaurant experience: A consumer perspective towards Korean restaurants. *Tourism Recreation Research, 41*(2), 199–212. <https://doi.org/10.1080/02508281.2016.1151163>
- Joo, Y., Seok, H., & Nam, Y. (2020). The moderating effect of social media use on sustainable rural tourism: A theory of planned behavior model. *Sustainability, 12*(10), 4095.
- Kadilar, C., & Cingi, H. (2005). A New Ratio Estimator in Stratified Random Sampling. *Communications in Statistics - Theory and Methods, 34*(3), 597–602. <https://doi.org/10.1081/STA-200052156>
- Kang, H. (2021). Sample size determination and power analysis using the G\*Power software. *Journal of Educational Evaluation for Health Professions, 18*. <https://doi.org/10.3352/jeehp.2021.18.17>
- Kapferer, J.-N., & Valette-Florence, P. (2022). The myth of the universal millennial: Comparing millennials' perceptions of luxury across six countries. *International Marketing Review, 39*(2), 149–165. <https://doi.org/10.1108/IMR-04-2021-0155>
- Keller, K. L., Parameswaran, M. G., & Jacob, I. (2011). *Strategic brand management: Building, measuring, and managing brand equity*. Pearson Education India.
- Ketter, E. (2020). Millennial travel: Tourism micro-trends of European Generation Y. *Journal of Tourism Futures, 7*(2), 192–196. <https://doi.org/10.1108/JTF-10-2019-0106>
- Khamaludin, K., Syam, S., Rismaningsih, F., Lusiani, L., Arlianti, L., Herlani, A., Fahlevi, M., Rahmadi, R., Windyarsari, V., & Widiyatun, F. (2022). The influence of social media marketing, product innovation and market orientation on Indonesian SMEs marketing performance. *International Journal of Data and Network Science, 6*(1), 9–16. <https://doi.org/10.5267/j.ijdns.2021.11.002>
- Kotler, P., & Armstrong, G. (2018). *Principles of Marketing 17th Global Edition*.
- Kraus, S., Sen, S., Savitskie, K., Kumar, S. K., & Brooks, J. (2022). Attracting the millennial customer: The case of food trucks. *British Food Journal, 124*(13), 165–182. <https://doi.org/10.1108/BFJ-09-2021-0996>
- Kumar, A., Bezawada, R., Rishika, R., Janakiraman, R., & Kannan, P. K. (2016). From Social to Sale: The Effects of Firm-Generated Content in Social Media on Customer Behavior. *Journal of Marketing, 80*(1), 7–25. <https://doi.org/10.1509/jm.14.0249>
- Lahath, A., Omar, N. A., Ali, M. H., Tseng, M.-L., & Yazid, Z. (2021). Exploring food waste during the COVID-19 pandemic among Malaysian consumers: The effect of social media, neuroticism, and impulse buying on food waste. *Sustainable Production and Consumption, 28*, 519–531. <https://doi.org/10.1016/j.spc.2021.06.008>
- Lee, D., Hosanagar, K., & Nair, H. S. (2018). Advertising Content and Consumer Engagement on Social Media: Evidence from Facebook. *Management Science, 64*(11), 5105–5131. <https://doi.org/10.1287/mnsc.2017.2902>
- Lee, T. W., & Govindan, S. (2014). Emerging issues in car purchasing decision. *Academic Research International, 5*(5), 169.
- Liao, C., Chen, J.-L., & Yen, D. C. (2007). Theory of planning behavior (TPB) and customer satisfaction in the continued use of e-service: An integrated model. *Computers in Human Behavior, 23*(6), 2804–2822. <https://doi.org/10.1016/j.chb.2006.05.006>
- Lind, D. A., Marchal, W. G., & Wathen, S. A. (2018). *Statistical Techniques in Business & Economics* (17th ed., p. 897). McGraw Hill Education.
- Lu, Y.-C., & Chen, K.-N. (2017). Consumer Knowledge, Brand Image, Openness to Experience and Involvement: A Case in Cosmetic Consumption. *Journal of Cosmetics, Dermatological Sciences and Applications, 7*(4), Article 4. <https://doi.org/10.4236/jcdsa.2017.74031>
- Mangold, W. G., & Faulds, D. J. (2009). Social media: The new hybrid element of the promotion mix. *Business Horizons, 52*(4), 357–365. <https://doi.org/10.1016/j.bushor.2009.03.002>
- Marhaeni, A. A. I. N., Yasa, I. G. W. M., & Fahlevi, M. (2022). Gender and age in the language of social media: An easier way to build credibility. *International Journal of Data and Network Science, 6*(1), 209–216. Scopus. <https://doi.org/10.5267/J.IJDNS.2021.9.007>
- Martinez-Ruiz, M. P., & Gómez-Cantó, C. M. (2016). Key External Influences Affecting Consumers' Decisions Regarding Food. *Frontiers in Psychology, 7*. <https://www.frontiersin.org/articles/10.3389/fpsyg.2016.01618>
- Maskuroh, N., Fahlevi, M., Irma, D., Rita, R., & Rabiah, A. (2022). Social media as a bridge to e-commerce adoption in Indonesia: A research framework for repurchase intention. *International Journal of Data and Network Science, 6*(1), 107–114. <https://doi.org/10.5267/j.ijdns.2021.9.017>
- Matroji, F. J., Mulyadi, K. P., Dandi, M., & Fahlevi, M. (2023). Digital Influencers: Shaping Our Brand Choices and Purchase Intentions? A Moderation by Gender Perspective. *E3S Web of Conferences, 426*, 01050. <https://doi.org/10.1051/e3sconf/202342601050>
- Muñoz-Leiva, F., Hernández-Méndez, J., & Sánchez-Fernández, J. (2012). Generalising user behaviour in online travel sites through the Travel 2.0 website acceptance model. *Online Information Review, 36*(6), 879–902. <https://doi.org/10.1108/14684521211287945>
- Nedra, B.-A., Hadhri, W., & Mezrani, M. (2019). Determinants of customers' intentions to use hedonic networks: The case of Instagram. *Journal of Retailing and Consumer Services, 46*, 21–32. <https://doi.org/10.1016/j.jretconser.2018.09.001>



- Noviantoro, R., Maskuroh, N., Santoso, B., Abdi, M. N., Fahlevi, M., Pramono, R., Purwanto, A., Purba, J. T., Munthe, A. P., & Juliana. (2020). Did quality management system ISO 9001 version 2015 influence business performance? Evidence from Indonesian hospitals. *Systematic Reviews in Pharmacy*, 11(8), 499–507. Scopus. <https://doi.org/10.31838/srp.2020.8.71>
- Opoku, A., Duff, A., Yahia, M. W., & Ekung, S. (2024). Utilisation of green urban space for food sufficiency and the realisation of the sustainable development goals – UK stakeholders perspective. *Geography and Sustainability*, 5(1), 13–18. <https://doi.org/10.1016/j.geosus.2023.10.001>
- Orea-Giner, A., & Fusté-Forné, F. (2023). The way we live, the way we travel: Generation Z and sustainable consumption in food tourism experiences. *British Food Journal*, 125(13), 330–351. <https://doi.org/10.1108/BFJ-11-2022-0962>
- Quan, S., & Wang, N. (2004). Towards a structural model of the tourist experience: An illustration from food experiences in tourism. *Tourism Management*, 25(3), 297–305. [https://doi.org/10.1016/S0261-5177\(03\)00130-4](https://doi.org/10.1016/S0261-5177(03)00130-4)
- Raji, R. A., Rashid, S., & Ishak, S. (2019). The mediating effect of brand image on the relationships between social media advertising content, sales promotion content and behavioural intention. *Journal of Research in Interactive Marketing*, 13(3), 302–330. <https://doi.org/10.1108/JRIM-01-2018-0004>
- Rastogi, T., Agarwal, B., & Gopal, G. (2024). Exploring the nexus between sustainable marketing and customer loyalty with the mediating role of brand image. *Journal of Cleaner Production*, 440, 140808. <https://doi.org/10.1016/j.jclepro.2024.140808>
- Ringle, C. M., Sarstedt, M., Mitchell, R., & Gudergan, S. P. (2020). Partial least squares structural equation modeling in HRM research. *The International Journal of Human Resource Management*, 31(12), 1617–1643.
- Rosenbaum, M. S., Edwards, K., & Ramirez, G. C. (2021). The benefits and pitfalls of contemporary pop-up shops. *Business Horizons*, 64(1), 93–106. <https://doi.org/10.1016/j.bushor.2020.10.001>
- Sahir, S., Fahlevi, M., Kasbuntoro, K., & Sutia, S. (2021). Effect of halal food management system certification on buying interest of Indonesian consumer goods. *Uncertain Supply Chain Management*, 9(3), 731–738.
- Salmiah, S., Sahir, S., & Fahlevi, M. (2024). The effect of social media and electronic word of mouth on trust and loyalty: Evidence from generation Z in coffee industry. *International Journal of Data and Network Science*, 8(1), 641–654. <https://doi.org/10.5267/j.ijdns.2023.8.021>
- Sarita, S., & Suleman, J. (2017). *The relationship between the need to belong and instagram self-presentation among adolescents: Universitas Indonesia Psychology Symposium for Undergraduate Research*.
- Sarstedt, M., Ringle, C. M., & Hair, J. F. (2017). Partial least squares structural equation modeling. *Handbook of Market Research*, 26(1), 1–40.
- Saunders, M., Lewis, P., & Thornhill, A. (2009). *Research Methods for Business Students* (5th ed.). Prentice Hall.
- Schwemmer, C., & Ziewiecki, S. (2018). Social Media Sellout: The Increasing Role of Product Promotion on YouTube. *Social Media + Society*, 4(3), 2056305118786720. <https://doi.org/10.1177/2056305118786720>
- Sekaran, U., & Bougie, R. (2016). *Research methods for business: A skill building approach*. John Wiley & Sons.
- Shahbaz, M., Bilal, M., Moiz, A., Zubair, S., & Iqbal, H. (2020). Food safety and COVID-19: Precautionary measures to limit the spread of coronavirus at food service and retail sector. *Journal of Pure and Applied Microbiology*, 14(1), 749–756.
- Shestakofsky, B., & Kelkar, S. (2020). Making platforms work: Relationship labor and the management of publics. *Theory and Society*, 49(5), 863–896. <https://doi.org/10.1007/s11186-020-09407-z>
- Suleman, D., Suyoto, Y. T., & Prasetyo, T. (2022). How brand ambassador and trust on consumer purchase decisions of fashion products in the digital era. *Journal of Economics and Business Letters*, 2(4), Article 4. <https://doi.org/10.55942/jeb.l.v2i4.171>
- Sundararaj, V., & Rejeesh, M. R. (2021). A detailed behavioral analysis on consumer and customer changing behavior with respect to social networking sites. *Journal of Retailing and Consumer Services*, 58, 102190. <https://doi.org/10.1016/j.jretconser.2020.102190>
- Sutia, S., Riadi, R., Tukirin, Pradipta, I. A., & Fahlevi, M. (2023). Celebrity endorsement in social media contexts: Understanding the role of advertising credibility, brand credibility, and brand satisfaction. *International Journal of Data and Network Science*, 7(1), 57–64. Scopus. <https://doi.org/10.5267/j.ijdns.2022.12.006>
- Thach, L., Riewe, S., & Camillo, A. (2020). Generational cohort theory and wine: Analyzing how gen Z differs from other American wine consuming generations. *International Journal of Wine Business Research*, 33(1), 1–27. <https://doi.org/10.1108/IJWBR-12-2019-0061>
- Tsimonis, G., & Dimitriadis, S. (2014). Brand strategies in social media. *Marketing Intelligence & Planning*, 32(3), 328–344. <https://doi.org/10.1108/MIP-04-2013-0056>
- Tuten, T., & Mintu-Wimsatt, A. (2018). Advancing Our Understanding of the Theory and Practice of Social Media Marketing: Introduction to the Special Issue. *Journal of Marketing Theory and Practice*, 26(1–2), 1–3. <https://doi.org/10.1080/10696679.2018.1393277>
- van der Heijden, H. (2004). User Acceptance of Hedonic Information Systems. *MIS Quarterly*, 28(4), 695–704. <https://doi.org/10.2307/25148660>
- Villarejo Ramos, Á. F. (2002). *Modelos multidimensionales para la medición del valor de marca*. <https://idus.us.es/handle/11441/32792>
- Wardhani, E. P. (2016, January 15). Food Container, Contemporary “Food Court” Suitable for Hanging Out. *kompas.com*. <https://travel.kompas.com/read/2016/01/15/170200427/Food.Container.Food.Court.Kekinian.Cocok.untuk.Nongkrong>.
- We Are Social. (2022). *Digital 2022: Indonesia*. <https://wearesocial.com/id/>

- Wibowo, A., Chen, S.-C., Wiangin, U., Ma, Y., & Ruangkanjanases, A. (2021). Customer Behavior as an Outcome of Social Media Marketing: The Role of Social Media Marketing Activity and Customer Experience. *Sustainability*, *13*(1), Article 1. <https://doi.org/10.3390/su13010189>
- Yuan, J. J., Bauman, M. J., Ferns, B. H., Ebrahimzadeh, M., & Alshiha, A. A. (2023). Restaurant Dining Environment, Restaurant Formality and Dining Involvement in the Context of Memorable Dining Experiences (Mdes). *Journal of Quality Assurance in Hospitality & Tourism*, *24*(6), 957–984. <https://doi.org/10.1080/1528008X.2022.2094848>
- Zhu, J., Jiang, L., Dou, W., & Liang, L. (2019). Post, Eat, Change: The Effects of Posting Food Photos on Consumers' Dining Experiences and Brand Evaluation. *Journal of Interactive Marketing*, *46*(1), 101–112. <https://doi.org/10.1016/j.intmar.2018.10.002>



© 2024 by the authors; licensee Growing Science, Canada. This is an open access article distributed under the terms and conditions of the Creative Commons Attribution (CC-BY) license (<http://creativecommons.org/licenses/by/4.0/>).