

## Assessing supply chain performance through the interplay among success drivers

Mohammad A.K. Alsmairat<sup>a\*</sup>, Raid Al-Adaileh<sup>b</sup>, Moh'd Anwer AL-Shboul<sup>c</sup> and Hasan Balfaqih<sup>d</sup>

<sup>a</sup>Luminus Technical University College, Jordan

<sup>b</sup>Skyline University College UAE; Mutah university Jordan

<sup>c</sup>Princess Sumaya University for Technology (PSUT), Jordan

<sup>d</sup>Supply Chain Management Department, College of Business Administration (CBA), University of Business and Technology (UBT), Kingdom of Saudi Arabia

### ABSTRACT

#### Article history:

Received December 15, 2021

Received in revised format

December 28, 2021

Accepted April 24 2022

Available online

April 24 2022

#### Keywords:

Supply chain integration

Supplier Relationship

Supply chain Innovation

Performance

This study examines the success drivers of Supply Chain Performance (SCP). This study aims to examine the interrelationships among various proposed success drivers of SCP that were analyzed individually or collectively in some previous studies. Four proposed forces have been identified in this study including organizational culture, SC relationships, SC integration, and SC innovation. SC integration is seen as a mediating factor between SC relationships and SCP. Using a deductive and quantitative approach that is based on collecting data from (17) companies in the field of logistics using an online survey, the study focuses on four success drivers including organizational culture, SC innovation, SC relationships, and SC integration. Smart PLS 3 software was applied to analyze the data based on the use of Structural Equation Modelling (SEM). The findings confirm that organizational culture and SC innovation have a direct significant impact on SCP. Regarding the mediating role of SC integration, the finds confirmed that SC integration mediates the relationship between SC relationships and SCP. A set of implications and recommendations for decision-makers and researchers are proposed based on the empirical findings of the current study. SC managers must first consider organizational culture and try to create positive supportive cultural attributes. A culture that encourages openness to change, sharing of knowledge, and collaboration seems a necessity to further improve SCP. Additionally, as the study findings emphasized the significant impact of SC innovation, SC managers should encourage innovative initiatives and behavior.

© 2022 Growing Science Ltd. All rights reserved.

## 1. Introduction

Due to the development in the business environment and marketplace, business is becoming riskier and more challenging nowadays (Christopher et al., 2011). Companies need to think and be more competitive as the world of business is getting complex with high expectations of customers. One way to realize this is to focus attention on the supplier-customer relationship, which can enable strong collaboration with suppliers and customers and foster business performance (Nwachukwu et al., 2021). Risk, challenges, and problems facing any business are affecting the SC Performance (SCP) and making it more difficult, and complicated. A SC (SC) is a set of entities and processes including suppliers, factories, distributors, retailers, and customers that are involved in fulfilling a customer order (Alsmairat, 2021; Ben-Daya, 2019). It refers to every input that is needed to produce a product or deliver a service and fulfill a certain need (Alzoubi, 2022). SC is not only manufacturers and suppliers, but also includes and depends on (logistic flow), transportation, warehouse, retailers, and consumers (Chopra, 2001). SC is a set of ordered processes starting from the design of new products and services, procuring raw materials, transforming them into semi-finished and finished products, and delivering them to the end customers (Xiaoyuan & Swaminathan, 2015).

\* Corresponding author

E-mail address [M.alsmairat@ltuc.com](mailto:M.alsmairat@ltuc.com) (M. A.K. Alsmairat)

© 2022 Growing Science Ltd. All rights reserved.

doi: 10.5267/j.uscm.2022.4.003

SCP describes feedback on processes and operations regarding customer satisfaction, which leads organizations to measure their performance and action to improve operations to be more efficient and effective (Bhagwat & Sharma, 2007). To gain a sustainable performance, the organization must have knowledge and background about the performance of its SC. Additionally, identification and clear understanding of some possible influencing factors including SC integration, SC relationships, technological, cultural, and many other factors on the performance of SC seems crucial to improve the overall organizational effectiveness and efficiency.

The increasing importance of SC practices and the new technological developments that are shaping the practices of SC (e.g. Internet of Things, Big data, blockchain) in addition to the new emerging business models are calling for reconsideration of the driving forces of SC performance (Kshetri, 2018). Moreover, analysis of interrelationships among these driving forces seems critical to formulating a SC strategy that can be aligned with the overall business strategy. SCs are operating under ever-changing internal and external, local and global environments and are vulnerable to numerous changes at all levels ((Ben-Daya, 2019). Accordingly, testing and re-testing of the success driver of SCP seem also a continuous research domain, which provides a motivation to conduct this study.

This study aims to examine the interrelationships among various proposed success drivers of SCP that were analyzed individually or collectively in some previous studies. Four proposed forces have been identified in this study including organizational culture, SC relationships, SC integration, and SC innovation. SC integration is seen as a mediating factor between SC relationships and SCP.

## **2. Theoretical Background and Hypotheses Development**

### *2.1 Organizational Culture and Supply Chain Performance*

Organizational culture is shared by people and groups in an organization and controls the way they interact with each other and with stakeholders outside the organization. This study contends that SCP is influenced by organizational culture. Employees are guided by shared values in both internal and external activities, such as the formation of buyer-supplier relationships (Schilke & Cook, 2014). Additionally, management and operational methods are built on the foundation of organizational culture (Braunscheidel et al., 2010). Furthermore, (López et al. 2004) found a strong link between organizational culture and organizational learning. In a recent study, Sriyakul et al., (2019) indicated that cultural traits, transformational leadership, and commitment to change have a positive role in SC operational excellence as well as the overall organizational performance. Organizational culture may help SC managers by creating an environment where organizations can learn from SC partners (Qi et al., 2011). Furthermore, firms that are willing to integrate in terms of trust and relationship commitment aggressively integrate both internally and externally, allowing them to successfully foster cooperation (Chen et al., 2013). Baz., et al (2021) have conducted a comprehensive literature review assessing the role of cultural dimensions in SC management and concluded that such research is still lacking. With the extended scope of SC activities into an international domain, the importance of culture seems even more significant. The alignment between organizational culture and SC management can further improve both SCP and the overall organizational performance (Zanon., 2021). As a result, this study argues that organizational culture will have a substantial impact on SCP as an integral part of a firm's operational practice.

**H<sub>1</sub>:** *Organizational culture has a significant impact on SCP.*

### *2.2 Supply Chain Innovation*

New products are becoming increasingly complex, involving an increasing number of stakeholders. Thus, it is not always possible for the company to be the driver of innovation. Research indicates that it is often a collective and open process (Alsmairat, 2021). The development and innovation in the processes of transportation, delivery, supply, and many implementation skills in the company in the form of a new product or a new service are expected to influence SCP. Innovations allow remarkable development within the company through modern technological systems and innovative SC practices (Maniak & Midler 2008). SC innovation has been widely accepted as an important ingredient for improving not only SCP but also the overall organization (Krishnan et al., 2021).

Solaimani and van der Veen (2021) analyzed the concept of open innovation in SC settings based on three ambidextrous capabilities including purpose (i.e. knowledge exploration and exploitation), span (horizontal and vertical collaboration), and orientation (i.e. incremental and radical innovation). They argued that SC innovation could be nurtured through joint efforts between firms and their SC partners which could improve SCP. Moreover, innovation involves the development and application of new ideas and models of knowledge gained through research or experimentation with the aim of testing and evaluating the conditions that allow the realization of a technical innovation project. Tebaldi et al. (2018) based on a systematic review of the literature stated that SC innovation can lead to a more sustainable SCP. Accordingly, the level of innovativeness is expected to improve the performance of SC, which proposes the following hypothesis:

**H<sub>2</sub>:** *SC Innovation has a significant impact on SCP.*

### 2.3 Supply Chain Relationships and Integration

SC Relationships can improve customer service and cut costs by allowing members of the SC to communicate with one another. Supplier relationships that pursue balanced knowledge integration can fully leverage synergies that lead to improved efficiency and innovation (AL-Shboul et al., 2018; Adebajo et al., 2018). If both parties or more feel more satisfied with the relationship, they can gain benefits and communicate more effectively. Any conflicting issue may also be discussed and easily resolved. According to Lee & Ha (2018), organizations should pay attention to having social interactions with partners to promote trust in the relationship for efficiency in information sharing. A cooperative relationship depends largely on how the parties develop that relationship over time, negotiation of the initial agreement is subsequently encouraging organizations to engage in more frequent and more successful joint strategic initiatives affecting their operation and the overall performance of the SC (Alsmairat & Aldakhil, 2022; AL-Shboul et al., 2017). SC relationships with customers may also encourage the development of new innovative capabilities that in turn enable improved manufacturing performance (Adebajo et al., 2018).

SC integration is the step in which a factory collaborates strategically with its SC partners and collaboratively manages operations within the organization to achieve efficient flows of products, services, information, money, and decisions and to provide maximum value to the customer. Creating an integration strategy between internal functions, suppliers, and customers can achieve competitive advantages (Madhani,2017) and improve performance (Smart, 2008). SC integration, internal integration, and customer integration may have strong implications to meet the needs and requirements and to deliver the right product in the right place at the right time with a high quality and appropriate cost (Rizzi et al., 2021).

Furthermore, previous studies showed that SC integration and information sharing improved SCP (Saleem et al.,2020; AL-Shboul et al., 2017). Integration between suppliers and customers may lead to improving the performance of operations (Siagian et al.,2020). On the other hand, there is a strong relationship between drivers of SC integration, supplier integration, customer integration, information, and internal process which leads to cost reduction in the SC (Ganbold et al.,2020; Chavez et al., 2015; Abdallah et al., 2014). Supplier integration represents the participation of all suppliers in making the right operations decisions in the organization while sharing important information related to demand and production (AL-Shboul et al., 2018). The relationship between the supplier and company must be strong to improve lead time and innovation (Duhaylongsod & Giovanni, 2018). Shukor et al., (2018) stated that business managers' relationships are positively related to SC integration. They argued that supplier and customer integration contribute to firm performance. Moreover, customer integration in the SC gives organizations the ability and opportunity to know and organize customer needs, expectations, and satisfaction of their requirements (Neutzling et al., 2018). Therefore, it is necessary to have mutual and integrated information with customers (Tarigan et al.,2021; González-Gallego et al., 2015). Efficiency improvement requires a high level of integration between all the parties especially with a customer as such integration is expected to lead to the fastest response. To test the potential impact of SC integration on SCP, the following hypothesis is proposed:

This study argues that the development of closer relationships in SC can improve SC integration, which leads to more flexibility and better SCP (Munir et al., 2020; AL-Shboul et al., 2018; Chaudhuri et al., 2018). The basic concept of integration depends on the nature and strength of the network of the relationships. According to Neutzling et al. (2018), collaborative relationships with suppliers and buyers are seen as a source of learning and new information. A trust-based relationship can encourage collaboration among SC entities and improve understanding and potentially satisfy all stakeholders' interests, which definitely improves performance (Khan & Wisner, 2019). To revalidate this argument, the following hypothesis is proposed to test the mediating role of SC integration.

**H<sub>3</sub>:** SC Integration has a significant mediating impact on the relationship between SC relationship and SCP.

The following model represents the hypotheses of this study (see figure 1):

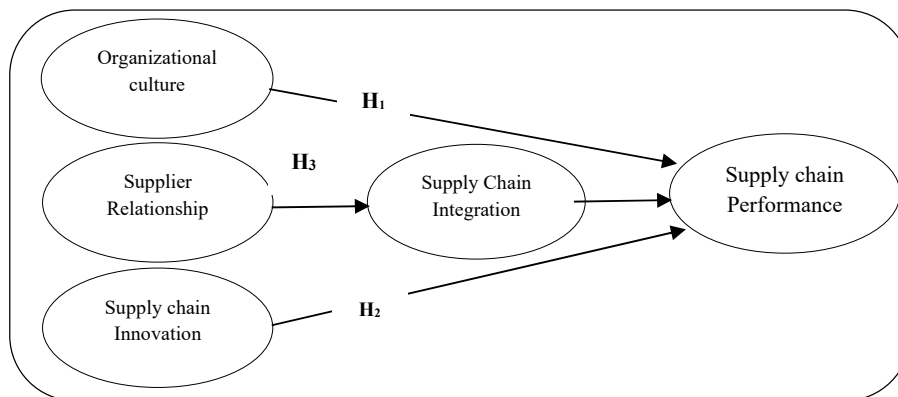

**Fig. 1.** Conceptual model of the study

### 3. Research Methodology

The current study aims to investigate the SCP through the interplay among success drivers. The study mainly used deductive and quantitative approaches by using an online survey. A convenient sample method was applied. The researchers selected (17) companies in the field of logistics. Logistics employees and managers were the target sample of this study. (167) respondents were collected and analyzed. The questionnaire was written in English and translated into Arabic as the native language for respondents. The questionnaire was divided into four sections. The first section embraces the demographic variables including gender, age, and educational level. The second section includes the respondent's perspectives of SC drivers in four drivers: SC integration (5 items); organizational culture (6 items); SC innovation (5 items); SC relationships (6 items). Items were adapted from (Yunus, 2018; Saleh, 2015). Fig. 2 summarizes the descriptive statistics of the demographic variables.

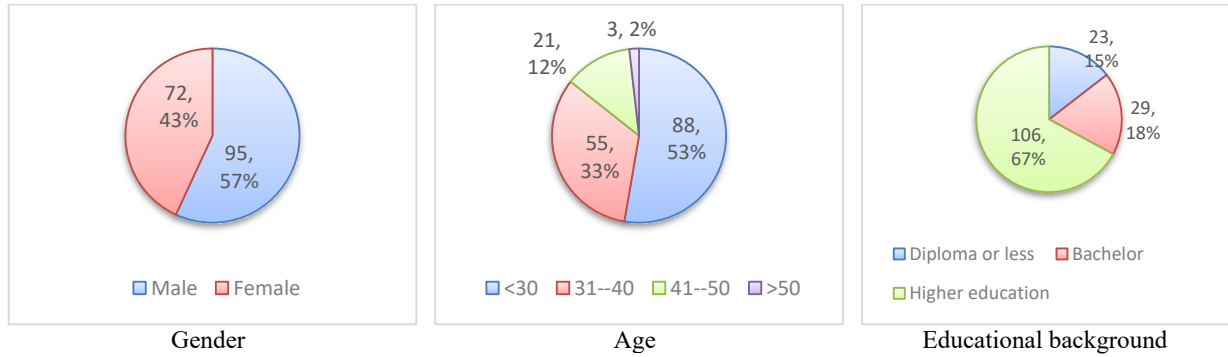

Fig. 2. Sample Characteristics

Smart PLS 3 software was used to conduct Structural Equation Modelling (SEM) following the recommendations of (Sarstedt & Hair et al., 2021). The model was measured using 5000 bootstraps according to the recommendations by (Henseler et al., 2016). However, the next subsection presents the results.

### 4. Data Analysis

Validity and reliability analysis for research instrument were measured. In line with (Hair et al., 2017), these were conducted by applying Cronbach's Alpha; composite reliability (CR); Average Variance Extracted (AVE). Accordingly, all indices reveal the good reliability and validity of the constructs and exceed the cut-off values (CR>0.60; Alpha>0.60; AVE>0.50). Table 1 summarizes these findings.

Table 1  
Scale validity and reliability

Constructs	Alpha Cronbach's	Composite Reliability (CR)	AVE
Organizational culture	0.889	0.915	0.642
Supplier Relationship	0.860	0.893	0.544
SC Integration	0.790	0.856	0.546
SC Innovation	0.871	0.907	0.660
SC Performance	0.870	0.903	0.607

Besides, correlations by conducting Pearson bivariate analysis for all all-research variables, and the findings reveal that no multicollinearity concerns amid the research constructs and Table 2 show these findings.

Table 2  
Discriminant validity

Constructs	OC	SR	SCI	SCIInno	SCP
Organizational culture (OC)	0.802				
Supplier Relationship (SR)	0.842	0.738			
SC Integration (SCI)	0.723	0.807	0.739		
SC Innovation (SCIInno)	0.873	0.783	0.722	0.813	
SC Performance (SCP)	0.846	0.773	0.707	0.850	0.779

The SEM (see Fig. 3 and Table 3) was assessed by checking path coefficients and the R<sup>2</sup> values. More so, both direct and indirect effects were evaluated to ensure that the mediation effect was checked following the (Zhao et al., 2010) recommendations.

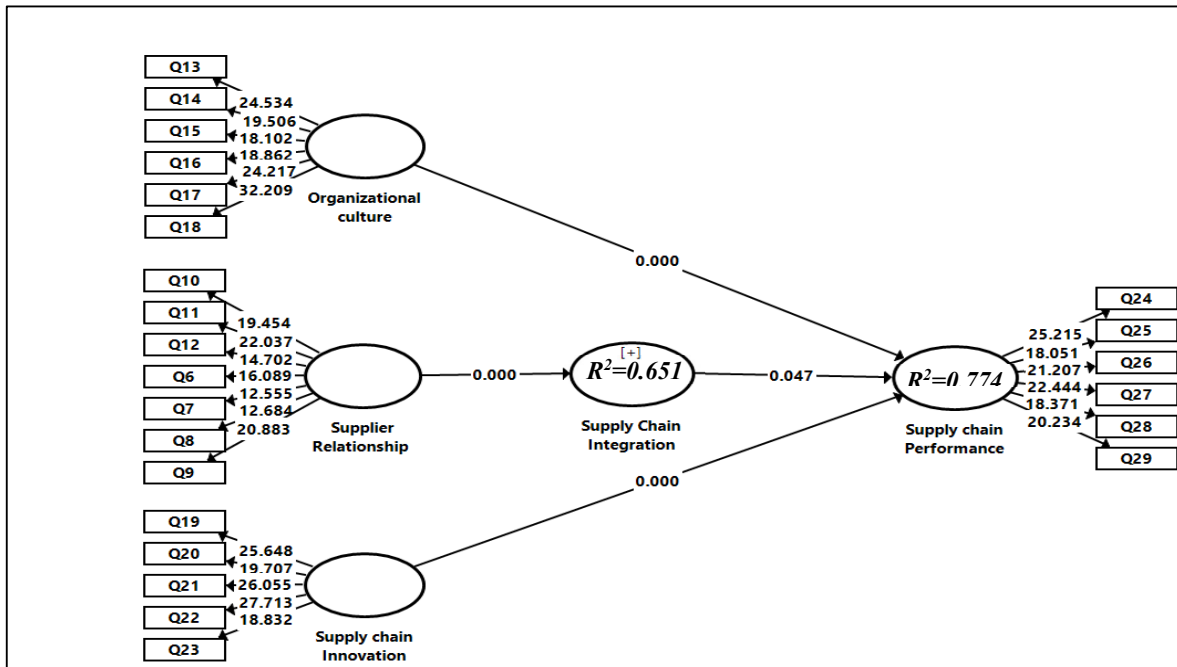

Fig. 3. Path Model

Table 3

Path analysis

IV	DV	$\beta$	S.E	t - value	P-value
Organizational culture	SCP	0.390	0.091	4.271	0.000
SC Innovation	SCP	0.424	0.085	4.985	0.000

IV	Mediator	DV	$\beta$	t - value	Confidence Level LO -UP	P value
SC Relationships	SC Integration	SC Performance	0.096	1.979	(0.001-0.191)	0.048

As represented in Fig. 3, the values of R<sup>2</sup> of the research variable SC integration and SCP were 0.651; 0.774 respectively, which advocates that the model provides a proper explanation and its predictive power is meaningful. Furthermore, the H1 predicted that organizational culture is positively and directly associated with the SCP. This hypothesis is accepted as the path between these constructs is supported and significant at p < 0.01; and ( $\beta=0.390$ ;  $t=4.271$ ). Moreover, the second hypothesis predicted that SC innovation is positively and directly associated with the SCP. This hypothesis also is accepted as the path between these constructs is supported and significant at p < 0.01; and ( $\beta=0.424$ ;  $t=4.985$ ).

The third hypothesis supposes that SC Integration has a significant mediating impact on the relationship between SC relationship and SCP. Specifically, the mediating effect of the mediators was assessed using indirect effect analysis and 95% confidence interval following Preacher et al., (2007) recommendations. Results reveal that the standardized indirect effect (mediation path) of supplier relationship on the SCP through SC integration was (0.096) and (p= .000, 95% confidence interval: 0.01– 0.191). As such, H3 received empirical support. Thus, we can say that supplier relationship influences the overall SCP of logistics companies through the mediating variable of SC integration. In other words, a one-unit increase in supplier relationship will increase the SCP through SC integration by 9%.

5. Discussion

This study contributes to the SCP literature and adds some insights considering the success drivers of SCP. The study examines four important success drivers including organizational culture, SC innovation, SC relationships, and SC integration. Organizational culture and SC innovation are found to have a significant positive impact on SCP. Additionally, the findings revealed that SC integration is mediating the relationship between SC relationship and SCP. The elastic and holistic nature of cultural attributes can create a supportive organizational environment that promotes adaptable and agile SC practices (Zanon, 2021; Sriyakul et al., 2019). Positive cultural attributes may include openness to change, resilience, cooperative relationship, and knowledge sharing not only within the organizational context but also with external stakeholders. As the scope of SC practices is extending from local into global settings, one could argue that the importance, as well as the complexity of cultural attributes, will continue to increase.

Furthermore, SC innovation is becoming a critical requirement of acceptable and competitive SCP. With the introduction of new emerging technology and the digital transformation of today's business, innovative SC practices must be developed. Big data, Blockchain, Internet of Things, cloud computing, and other emerging and constantly developing technology will surely shape the future of SC. The outcomes and justification of this particular finding is supported by many previous studies (e.g. Alsmairat, 2022; Solaimani & van der Veen, 2021; Hahn, 2020; Kwak et al., 2018). The fourth industrial revolution enabled SC innovation to extend the initial focus on productivity improvements in SC practices towards scalability and flexibility with technology-driven solutions (Hahn, 2020).

SC integration as shown by the findings of this study is mediating the interrelationship between SC relationships and SCP. Indeed, building and maintaining a network of relationships among all SC players can lead to a better understanding of the interests of all and accordingly to better integration and better SCP. SC integration also influences the cost and operational efficiency (Ganbold et al., 2020; Duhaylongsod & De Giovanni, 2018) that are directly linked to SCP. Additionally, SC integration can improve SC agility and adaptability (Khan & Wisner, 2019). In today's technology-driven environment, emerging technologies like Internet of Things can post internal, customer, and supplier-related process integration that in turn positively affects supply chain performance (De Vass et al., 2018). Similarly, Rizzi (2021) argued that logistic integration can significantly influence SCP and mediate the relationship between SC capability and SCP.

## 6. Implications and Recommendations

The findings of this study have several implications for policy and decision-makers as well as a researcher within the domain of SC practices and SCP. SC managers must first consider organizational culture and try to create positive supportive cultural attributes. A culture that encourages openness to change, sharing of knowledge, and collaboration seems a necessity to further improve SCP. Additionally, as the study findings emphasized the significant impact of SC innovation, SC managers should encourage innovative initiatives and behavior. Looking openly to the external environment to identify best practices and available opportunities. Introducing new technologies must be seen as a strategic SC investment to improve SCP.

Regarding SC relationship and integration, SC managers are invited to strengthen the web of relationships on the internal and external levels. This can encourage building a cooperative environment and better integration among SC stakeholders, which as this study revealed, could improve SCP.

This study contributes to the current stream of literature concerning SCP. It confirms the previous studies' outcomes in a new context. It also adds some insights relating to the interrelationships among SC relationship, SC integration, and SCP. A mediating role of SC integration is confirmed which emphasizes the importance of SC integration among all SC stakeholders. Since the current study focused only on four driving forces of SCP and considering the complexity of SC practices and stakeholders, future research could investigate other forces to meet the new so-called e-supply chain practices. The feasibility of new technologies seems a potential area of future studies.

## References

- Abdallah, A. B., Obeidat, B. Y., & Aqqad, N. O. (2014). The impact of supply chain management practices on supply chain performance in Jordan: The moderating effect of competitive intensity. *International Business Research*, 7(3), 13.
- Adebanjo, D., Teh, P. L., & Ahmed, P. K. (2018). The impact of supply chain relationships and integration on innovative capabilities and manufacturing performance: the perspective of rapidly developing countries. *International Journal of Production Research*, 56(4), 1708-1721.
- Al-Shboul, M. A., Garza-Reyes, J., & Kumar, V. (2018). Best Supply Chain Management Practices and High- Performance Firms: The Case of Gulf Manufacturing Firms. *International Journal of Productivity and Performance Management*, 67(9), 1482-1509.
- AL-Shboul, M., Barber, K., Garza-Reyes, J., Kumar, V., & Abdi, M. R. (2017), The effect of supply chain management practices on supply chain and manufacturing firms' performance. *Journal of Manufacturing Technology Management*, 28(5), 577-609.
- Alsmairat, A. K. (2021). Transformative supply chain drivers during covid-19: A customer perspective. *Polish Journal of Management Studies*, 24(2).
- Alsmairat, M. (2021). Toward digitalization era in supply chain: a mediation model of success drivers. *Academy of Strategic Management Journal*, 6(6).
- Alsmairat, M., & Aldakhil, A. (2022). Modeling the interrelationships among environmental forces, organizational capabilities and supply chain sustainability. *Uncertain Supply Chain Management*, 10(1), 117-124.
- Alsmairat, M. A. (2022). The nexus between organizational capabilities, organizational readiness and reverse supply chain adoption. *Acta Logistica*, 9(1), 31-37.
- Alzoubi, H. M., Elrehail, H., Hanaysha, J. R., Al-Gasaymeh, A., & Al-Adaileh, R. (2022). The Role of Supply Chain Integration and Agile Practices in Improving Lead Time During the COVID-19 Crisis. *International Journal of Service Science, Management, Engineering, and Technology (IJSSMET)*, 13(1), 1-11.
- Baz, J. E., Jebli, F., Cherrafi, A., Akenroye, T., & Iddik, S. (2021). The cultural dimensions in supply chain management research: a state-of-the-art review and research agenda. *European Business Review*, 34(2), 171-190.

- Ben-Daya, M., Hassini, E., & Bahroun, Z. (2019) Internet of things and SC management: a literature review. *International Journal of Production Research*, 57(15-16), 4719-4742.
- Bhagwat, R., & Sharma, M. K. (2007). Performance measurement of supply chain management: A balanced scorecard approach. *Computers & Industrial Engineering*, 53(1), 43-62.
- Braunscheidel, M. J., Suresh, N. C., & Boissier, A. D. (2010). Investigating the impact of organizational culture on supply chain integration. *Human Resource Management*, 49(5), 883-911.
- Chaudhuri, A., Boer, H., & Taran, Y. (2018). Supply chain integration, risk management and manufacturing flexibility. *International Journal of Operations & Production Management*, 38(3), 690-712.
- Chavez, R., Yu, W., Gimenez, C., Fynes, B., & Wiengarten, F. (2015). Customer integration and operational performance: The mediating role of information quality. *Decision Support Systems*, 80, 83-95.
- Chen, J., Sohal, A. S., & Prajogo, D. I. (2013). Supply chain operational risk mitigation: a collaborative approach. *International Journal of Production Research*, 51(7), 2186-2199.
- Chopra, S., & Meindl, P. (2001). *Strategy, planning, and operation. Supply Chain Management*.
- Christopher, M., Mena, C., Khan, O., & Yurt, O. (2011). Approaches to managing global sourcing risk. *Supply Chain Management: An International Journal*, 16(2), 67-81.
- De Vass, T., Shee, H., & Miah, S. J. (2018). The effect of “Internet of Things” on supply chain integration and performance: An organisational capability perspective. *Australasian Journal of Information Systems*, 22.
- Duhaylongsod, J. B., & De Giovanni, P. (2018). The impact of innovation strategies on the relationship between supplier integration and operational performance. *International Journal of Physical Distribution & Logistics Management*, 49(2), 156-177.
- Ganbold, O., Matsui, Y., & Rotaru, K. (2020). Effect of information technology-enabled supply chain integration on firm's operational performance. *Journal of Enterprise Information Management*, 34(3), 948-989.
- González-Gallego, N., Molina-Castillo, F. J., Soto-Acosta, P., Varajao, J., & Trigo, A. (2015). Using integrated information systems in supply chain management. *Enterprise Information Systems*, 9(2), 210-232.
- Hahn, G. J. (2020). Industry 4.0: a supply chain innovation perspective. *International Journal of Production Research*, 58(5), 1425-1441.
- Hair Jr, J. F., Hult, G. T. M., Ringle, C. M., & Sarstedt, M. (2021). *A primer on partial least squares structural equation modeling (PLS-SEM)*. Sage publications.
- Hair, J., Hollingsworth, C. L., Randolph, A. B., & Chong, A. Y. L. (2017). An updated and expanded assessment of PLS-SEM in information systems research. *Industrial Management & Data Systems*, 117(3), 442-458.
- Henseler, J., Hubona, G., & Ray, P. A. (2016). Using PLS path modeling in new technology research: updated guidelines. *Industrial management & data systems*, 116(1).
- Khan, H., & Wisner, J. D. (2019). Supply chain integration, learning, and agility: Effects on performance. *Journal of Operations and Supply Chain Management*, 12(1), 14.
- Krishnan, R., Yen, P., Agarwal, R., Arshinder, K., & Bajada, C. (2021). Collaborative innovation and sustainability in the food supply chain-evidence from farmer producer organisations. *Resources, Conservation and Recycling*, 168, 105253.
- Kshetri, N. (2018). Blockchain's roles in meeting key supply chain management objectives. *International Journal of Information Management*, 39, 80-89.
- Kwak, D. W., Seo, Y. J., & Mason, R. (2018). Investigating the relationship between supply chain innovation, risk management capabilities and competitive advantage in global supply chains. *International Journal of Operations & Production Management*, 38(1), 2-21.
- Lee, C. H., & Ha, B. C. (2018). The impact of buyer-supplier relationships' social capital on bi-directional information sharing in the supply chain. *Journal of Business & Industrial Marketing*, 33(3), 325-336.
- Lopez, S. P., Peon, J. M. M., & Ordás, C. J. V. (2004). Managing knowledge: the link between culture and organizational learning. *Journal of Knowledge Management*, 8(6), 93-104.
- Madhani, P. M. (2017). Logistics and marketing integration: enhancing competitive advantages. *The IUP Journal of Management Research*, 16(3), 7-29.
- Maniak, R., & Midler, C. (2008). Shifting from co-development to co-innovation. *International Journal of Automotive Technology and Management*, 8(4), 449-468.
- Munir, M., Jajja, M. S. S., Chatha, K. A., & Farooq, S. (2020). Supply chain risk management and operational performance: The enabling role of supply chain integration. *International Journal of Production Economics*, 227, 107667.
- Neutzling, D. M., Land, A., Seuring, S., & do Nascimento, L. F. M. (2018). Linking sustainability-oriented innovation to supply chain relationship integration. *Journal of Cleaner Production*, 172, 3448-3458.
- Nwachukwu, C., & Hieu, V. M. (2021). Assessing Supplier-Customer Relationship Management Practice and Business Performance.
- Qi, Y., Zhao, X., & Sheu, C. (2011). The impact of competitive strategy and supply chain strategy on business performance: the role of environmental uncertainty. *Decision Sciences*, 42(2), 371-389.
- Rizzi, F., Annunziata, E., & Gigliotti, M. (2021). Greening SCM through SC integration: an exploratory investigation among Italian supply chain managers. *Sinergie Italian Journal of Management*, 39(3), 189-210.
- Saleem, H., Li, Y., Ali, Z., Ayyoub, M., Wang, Y., & Mehreen, A. (2020). Big data use and its outcomes in supply chain context: the roles of information sharing and technological innovation. *Journal of Enterprise Information Management*, 34(4), 1121-1143.

- Saleh, H. (2015). The Impact of Supply Chain Integration on Operational Performance at Jordanian Pharmaceutical Manufacturing Organizations. Middle East University, Amman, Jordan.
- Sarstedt, M., Hair, J. F., Ringle, C. M., Thiele, K. O., & Gudergan, S. P. (2016). Estimation issues with PLS and CBSEM: where the bias lies!. *Journal of Business Research*, 69(10), 3998-4010.
- Schilke, O., & Cook, K. S. (2015). *What Alliance Partners are Trustworthy? The Roles of Governance and Organizational Culture*. In *The Sustainable Global Marketplace* (pp. 270-270). Springer, Cham.
- Shukor, A. A. A., Newaz, M. S., Rahman, M. K., & Taha, A. Z. (2020). Supply chain integration and its impact on supply chain agility and organizational flexibility in manufacturing firms. *International Journal of Emerging Markets*, 16(8), 1721-1744.
- Smart, A. (2008). eBusiness and supply chain integration. *Journal of Enterprise Information Management*, 21(3).
- Solaimani, S., & van der Veen, J. (2021). Open supply chain innovation: an extended view on supply chain collaboration. *Supply Chain Management: An International Journal*.
- Sriyakul, T., Singa, A., Sutduean, J., & Jermittiparsert, K. (2019). Effect of cultural traits, leadership styles and commitment to change on supply chain operational excellence. *Journal of Computational and Theoretical Nanoscience*, 16(7), 2967-2974.
- Tarigan, Z., Jiputra, J., & Siagian, H. (2021). The effect of supply chain practices on retailer performance with information technology as moderating variable. *International Journal of Data and Network Science*, 5(1), 47-54.
- Tebaldi, L., Bigliardi, B., & Bottani, E. (2018). Sustainable supply chain and innovation: A review of the recent literature. *Sustainability*, 10(11), 3946.
- Xiaoyuan, L. L., & Swaminathan J. (2015) SC Management. *International Encyclopedia of Social and Behavioral Sciences*, 2nd edition, Vol 23.
- Yunus, E. N. (2018). Leveraging supply chain collaboration in pursuing radical innovation. *International Journal of Innovation Science*, 10(3), 350-370.
- Zanon, L. G., Marcelloni, F., Gerolamo, M. C., & Carpinetti, L. C. R. (2021). Exploring the relations between supply chain performance and organizational culture: A fuzzy grey group decision model. *International Journal of Production Economics*, 233, 108023.
- Zhao, X., Lynch Jr, J. G., & Chen, Q. (2010). Reconsidering Baron and Kenny: Myths and truths about mediation analysis. *Journal of Consumer Research*, 37(2), 197-206.



© 2022 by the authors; licensee Growing Science, Canada. This is an open access article distributed under the terms and conditions of the Creative Commons Attribution (CC-BY) license (<http://creativecommons.org/licenses/by/4.0/>).