

Uncertain Supply Chain Management

homepage: www.GrowingScience.com/uscm

Improvement of track zero to increase read/write area in hard disk drive assembly process

Prapod Ruthaiputpong and Napassavong Rojanarowan *

Department of Industrial Engineering, Faculty of Engineering, Chulalongkorn University, Bangkok, 10330, Thailand

CHRONICLE

Article history:

Received January 10, 2013
 Received in revised format
 19 July 2013
 Accepted July 19 2013
 Available online
 July 19 2013

Keywords:

*Six Sigma
 Defective Reduction
 Hard Disk Drive Assembly
 Process
 Track Zero
 Read/Write Area*

ABSTRACT

An improper machine setting in a hard disk drive assembly process could reduce the read/write area of hard disk drives. This paper presents the methodology to increase the read/write area of hard disk drives by finding an optimal machine setting that minimizes the track zero. The Six Sigma improvement approach was applied. The design of experiment technique helped indicate the optimal levels of significant factors, which were the number of screw turn, the rotating pin height, and the cylinder force, that yield the minimum track zero. The results showed that the mean of track zero was decreased from 16,185 to 15,120 tracks and the standard deviation was decreased from 1,116 to 633 tracks resulting in the increase of the process capability index (Ppk) of the track zero performance from 0.54 to 1.52.

© 2013 Growing Science Ltd. All rights reserved.

1. Introduction

In hard disk drive industry, the storage capacity of hard disk drives is a crucial quality characteristic. A hard disk drive consists of many components such as base desk, read/write head, disk, ramp, and voice coil magnet. All of them affect the drive performance and the storage capacity. The storage capacity is determined by the recording area of the disk. Disk reading/writing begins from the outer diameter zone of the disk (Track Zero) to the inner diameter zone of the disk (Track Maximum) as shown in Fig. 1. In order to increase the capacity of the hard disk drive, the track zero should be minimized, while the track maximum should be maximized. This paper focuses on increasing the performance regarding the track zero since the outer diameter has higher effect to the storage capacity than the inner diameter. There have been many research papers on hard disk storage capacity. However, most of them studied the design of a single component by using simulation programming.

Takaishi et al. (2003), Wong et al. (2003) and Jiguang et al. (2012) proposed the design of a magnetic disk by writing the special servo signals to generate more tracks on the outer recording zone.

* Corresponding author. Tel. +66-2218-6828

E-mail addresses: napassavong.o@chula.ac.th (N. Rojanarowan)

Furthermore, Lee et. al. (2005) proposed the new design of Voice Coil Motor (VCM) to reduce position error signal and improve dynamic characteristic of the actuator to obtain a large storage capacity. Moreover, the new ramp load/unload (L/UL) technology was designed to replace the contact start–stop technology (Suk & Albrecht, 2002). The ramp structure was merged into the disk area to define the track zero. The L/UL technology helped increase the drive capacity, obtain more efficient power utilization, and increase superior shock resistance. In addition, Kim et al. (2009) studied the ramp design to mitigate assembly and manufacturing errors resulting from the ramp geometric shape, which was one of the most dominant characteristic that affects the track zero.

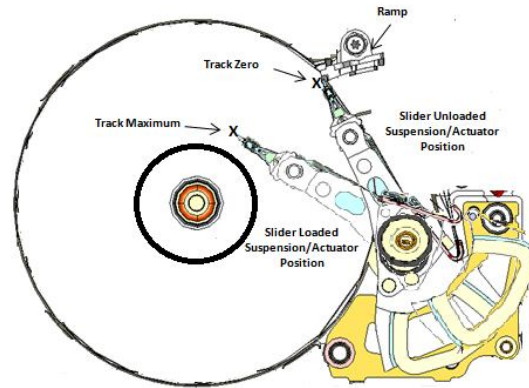

Fig. 1. Ramp Load/Unload technology in hard disk drive

Previous researches have focused on the design of hard disk drive components to improve the storage capacity but there are a few researches that study the real impact of manufacturing and assembly processes on the actual storage capacity. The ramp tilt effect during the assembly process has received much attention recently since it affects the track zero. The track zero point is determined during the unloading process in the mechanical testing process. While the read/write head is parking on the ramp structure, the lift tab moves out until it contacts the ramp limiter and then breaks at this point. The track zero point is defined by the offset of the contacted point to the inner zone as shown in Fig. 2a. The ramp has an upper side and a lower side. Both sides should align during the assembly process so that the read/write head contacts the ramp edge at the same time, resulting in a minimized track zero value as shown in Fig 2a. If the ramp is tilted during the assembly process as shown in Fig. 2b, the tracks where the lift tab contacts the ramp on both sides are different. Thus, the track zero is determined as the track that lies closer to the inner zone. The ramp tilt thus makes the track zero value greater.

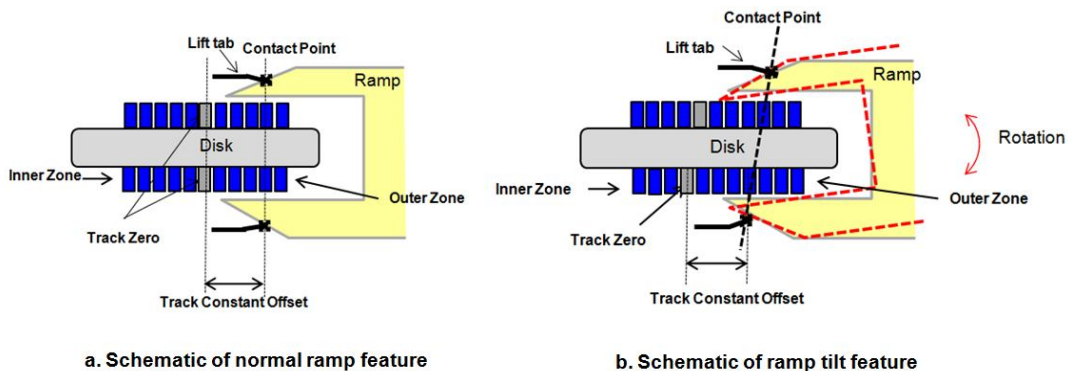

Fig.2. Effect of ramp tilt on track zero response

The machine parameter setting during the assembly process has significant effect on the ramp tilt, which results in poorer track zero performance. Therefore, this paper aims to improve the track zero performance by finding the optimal setting of the machine parameters that solve the ramp tilt problem. In order to find the optimal setting, the significant factors of the tilt problem have to be

identified. Statistical tools along with the knowledge of the hard disk drive assembly process are needed to find the significant factors and their best setting.

2. Assembly Process Description

The hard disk drive consists of several components which are spindle motor, voice coil motor (VCM), head stack assembly (HSA), top cover, and print circuit board assembly (PCBA). At the beginning of the assembly process, a disk is installed on a motor. Then, the assembled part is transferred to the ramp assembly machine. This machine is crucial to define the track zero. The ramp assembly machine is shown in Fig.3. There are several process factors involved in this machine. The mechanism of this machine is explained as follows. First the hard disk drive is re-torque with a screw driver which controlled by “the number of screw turn”. Next, the rod pin is inserted into the back ramp with “rotating pin height” setting. The actuator cylinder is controlled by a pneumatic source to obtain a proper force to push the ramp. This force is called “cylinder force”. Then, the ramp is pushed into the disk according to the “stopper distance”. The “compression spring” is used to absorb the force during the move. Finally, the ramp is tighten by a screw which controlled by a “ramp screw torque” and then transferred to the next assembly process. After all components have been assembled, the hard disk drives are tested by a mechanical testing process. HDD 2.5” Enterprise product is the main product of the company. The drives that have track zero values lower than 18,000 tracks are regarded as defectives. The proportion of defectives due to track zero parameter of this product is 51,929 DPPM.

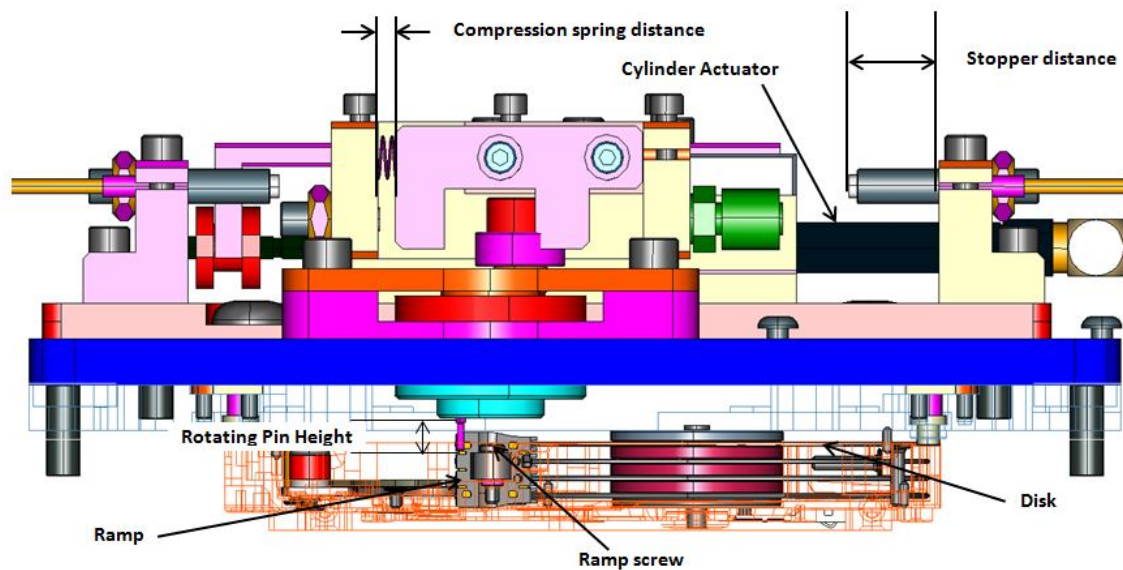

Fig.3. Ramp assembly machine

3. Methodology

Six sigma has been exploited by many world class organizations since 1980. It has the main objectives to decrease defectives, reduce cost, and create value (Klefsjö et al., 2001). Many leading manufacturing companies implement thousands of Six Sigma projects every year and this implementation demands a significant investment of capital that requires a careful analysis to make sure that the benefits obtained are much higher than the actual investment (Kumar et al., 2008). Six Sigma is a successful problem solving approach by utilizing a systematic methodology with an extensive set of statistical and advanced mathematical tools that yields significant results quickly (Raisinghani et al., 2005). It has been proven to be successful in increasing customer satisfaction and significantly increasing profitability (Antony et al., 2005).

The Six sigma methodology consists of five phases, which are Define, Measure, Analyze, Improve and Control (DMAIC) (Does et al., 2002). This paper demonstrates the use of Six Sigma approach to help increase the storage capacity of hard disk drives by minimizing track zero in the assembly process. In the Define phase, project charter and process map were written to describe the problem and current process. In the Measure phase, the measurement system and the process capability were analyzed to make sure that the current performance of the process is correctly understood. In the Analyze phase, the key process input variables (KPIVs) were identified and reduced to be investigated further in the next phase using the Cause-and-Effect Matrix. In the Improve phase, the design of experiment technique was used to test for the significance of the selected factors and to determine the optimal levels of the significant factors. In the Control phase, a control plan and other control tools, which were control charts and check list were set up to maintain the performance after improvement (Pyzdek, 2003).

4. Results

The following sections explain the results in each of the DMAIC steps.

4.1 Define Phase

In the define phase, the project charter needs to be written. The project charter consists of problem statement, objective statement, project scope, project metrics, project constraints, project assumptions, selected team members, and timeline. The project charter of this research project is shown in Table 1. This research aims to decrease the defective rate from read/write track zero defect from 51,929 to 10,386 DPPM and improve the process capability index (Ppk) from 0.54 to a standard acceptable value of 1.33 by December 31, 2012.

Table 1
Project Charter

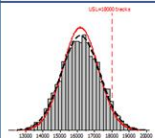
Six Sigma Project Charter		Project Title : Loss of Write/Read Track Zero Defect Reduction			
		Project Lead	Champion	Executive Sponsor	Master BlackBelt
		Prapod Ru.	Mongkol Tr.	John Emerson	Panya Si.
Problem Statement		Project Metrics			
 <p>Defective rate from read/write track zero defect of 2.5" hard disk drive is 51929 DPPM with the process capability index (Cpk) of 0.59 since July-November 2012.</p>		<p>Business Metric : Customer Satisfaction</p> <p>Primary Metric : Defective rate from track zero defect</p> <p>Secondary Metric : Utilization for rework line and warehouse</p> <p>Consequential Metric : Tooling Investment</p> <p>Financial Metric : Cost of scrap and rework</p>			
Objective Statement		Project Timeline			
<ul style="list-style-type: none"> - Decrease defective rate from read/write track zero defect from 51929 to 10386 DPPM by December 31, 2012. - Improve the Cpk to an acceptable standard value of 1.33 by December 31, 2012. 		Phase	Start	Finish	
		Define	07/01/2012	07/20/2012	
		Measure	07/21/2012	08/31/2012	
		Analyze	09/01/2012	10/20/2012	
		Improve	10/21/2012	11/30/2012	
		Control	12/01/2012	12/31/2012	
Project Scope		Project Assumptions			
The study and implementation are on 2.5" hard disk drive of production line L201.		<ul style="list-style-type: none"> - Champion supports the project and meet with team once a month. - Team has authority to do experiments and implement the solutions. 			
Project Constraints					
<ul style="list-style-type: none"> - Available time of team members for this projects 3 hours/week. - Budget to support projects 225000 baht. 					

4.2 Measure Phase

In this phase, first the performance of the measuring system was evaluated to make sure that it provided reliable measurements. Gage repeatability and reproducibility (GR&R) analysis was performed to compare the amount of variability due to the measurement system with the specifications (Precision to Tolerance ratio: P/T) and the amount of variation in the process (Precision to Total Variation: P/TV). The GR&R experiment with three measuring operators and two replicates was performed. The results in Table 2 showed that the P/T is 1.35% and the P/TV is 3.02%, were less

than the acceptable value of 10%. Thus, the measurement system has good precision enough to measure the process. Next, the process capability analysis was carried out to understand the current performance regarding the distribution of the track zero values compared to the specifications. Figure 4 showed the process capability data from July –November 2012. The mean of track zero parameter was 16,186 tracks and the variance was 1,116 tracks. The defective rate was 51,929 DPPM. The Ppk index of 0.54 suggesting that the process capability was not good enough since it was less than the standard acceptable value of 1.33 (Kotz & Lovelace, 1998).

Table 2

Gage repeatability and reproducibility (Gage R&R) study for track zero measurement

Source	StdDev (SD)	Study Variance (6 * SD)	%Study Variance (%SV)	% P/T
Total Gage R&R	20.05	120.30	1.35	3.02
Repeatability	15.45	92.67	1.04	2.33
Reproducibility	12.79	76.71	0.86	1.93
Operator	0.00	0.00	0.00	0.00
Operator * Parts	12.79	76.71	0.86	1.93
Part-To-Part	1483.00	8898.00	99.99	223.38
Total Variation	1483.14	8898.82	100.00	223.40

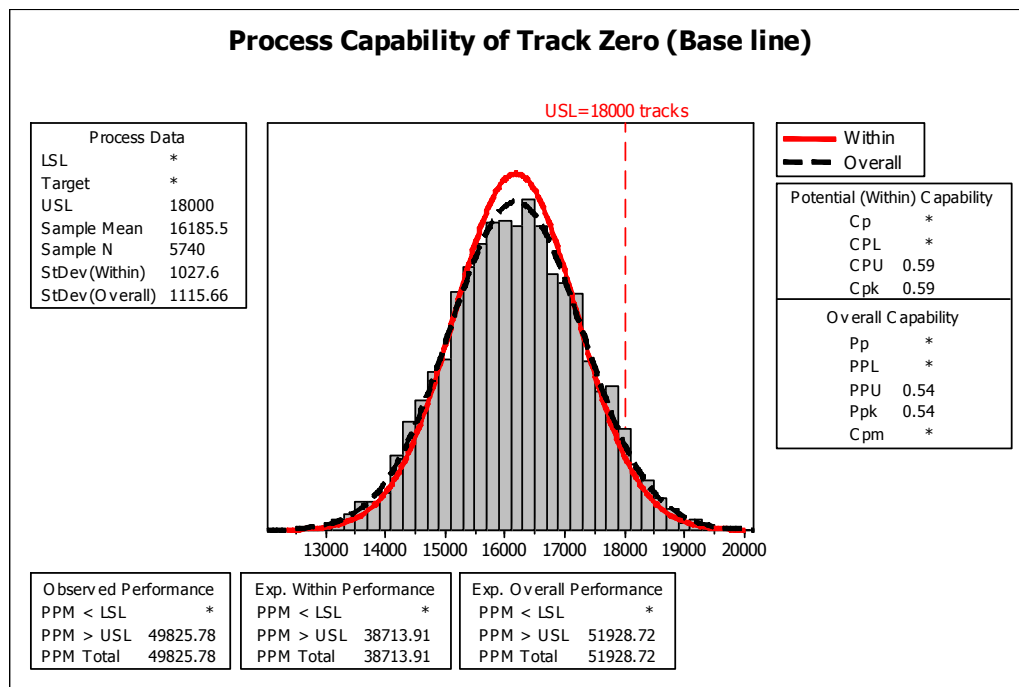

Fig.4. Process capability analysis for track zero (baseline)

Then, the potential causes of variation were brainstormed and prioritized to come up with the key process input variables using the Cause & Effect Matrix. The score rating led to six process variables to be tested for significance in the analysis phase.

4.3 Analyze Phase

Six process variables were selected to be tested further. These factors were the number of screw turn, rotating pin height, cylinder force, compression spring distance, ramp screw torque, and stopper distance. The design of experiment (DOE) technique with a 2^{6-1} fractional factorial design was used to screen for significant causes of track zero mean. The design was of resolution IV. The purpose of a screening experiment was to study the effects of a large number of factors efficiently (Shen & Wan, 2009). The center points were added to the factorial design to test whether there was a curvature

effect or the design was in the region of an optimum. Thus, this screening experiment consisted of 32 treatment runs at the corner points of the design space and four center points. The factors and levels of factors were displayed in Table 3.

Table 3
Process parameters for 2^{6-1} fractional factorial design

Symbol	Factors	Unit	Levels of Factors		
			Low	Center	High
A	Number of screw turn	round	0.25	0.75	1.25
B	Rotating pin height	mm.	4.0	8.0	12.0
C	Cylinder force	lbs	2.0	5.0	8.0
D	Compression spring distance	mm.	0.0	5.0	10.0
E	Ramp screw torque	in-lbs	1.0	1.3	1.6
F	Stopper distance	mm.	3.0	5.0	7.0

The statistical analysis of results started with the assumption checking. In order to analyze the results using ANOVA, the assumptions of Normally and Independently Distribution (NID) have to be checked using the residual analysis. Figure 6 showed the residual analysis, which showed that the residuals lie reasonably close to a straight line implying that errors are normally distributed. In addition, there was no noticeable pattern or unusual structure present in the data suggesting that the constant variance assumption was satisfied. Next, the normal probability plot of effects was used to identify the significant effects of track zero parameter. They were the main effects of A, B, and the interactions of AC and BC at the significance level of 0.05.

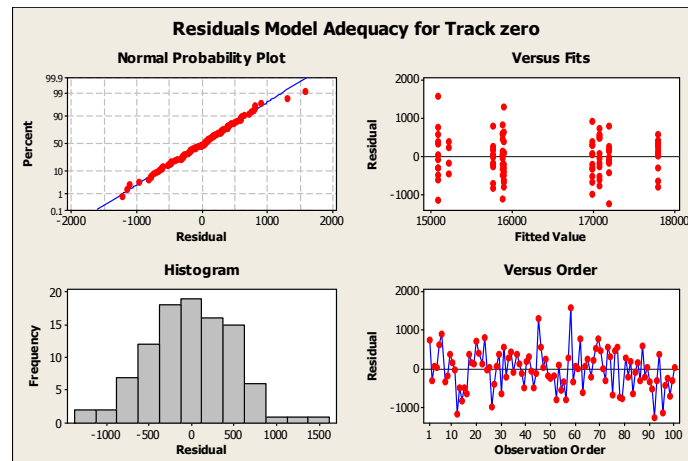
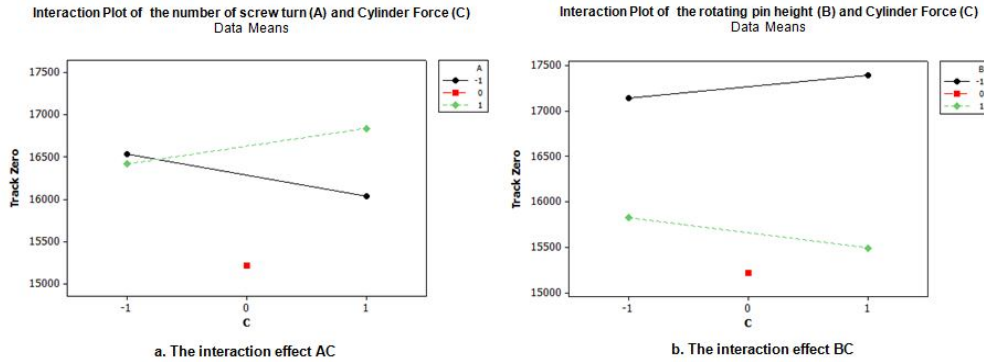

Fig.5. Residual plots for model adequacy check

The interaction effects have to be analyzed first if the main effects are significant (Montgomery, 2006). The interaction plots were shown in Fig. 6a and 6b. The interaction effect AC and BC significantly affected the track zero.

Next the interaction effect AC between the number of screw turn (A) and the cylinder force (C) was discussed. By the mechanism of machine, when the ramp screw was loosened with higher round of screw turn (A^+), if the cylinder force increased from 2.0 to 8.0 lbs, the track zero response was increased from 16,420 to 16,842 tracks. The reason was that when the ramp screw was loosened, the ramp bolting point can move more freely to the disk (see Fig. 7). When it was subjected to higher force, the ramp would tilt more and resulted in higher track zero as previously explained. Unlike when the ramp screw was tightened with lower round of screw turn (A^-), if the cylinder force increased from 2.0 to 8.0 lbs, the track zero response was decreased from 16,540 to 16,035 tracks. The reason was that when the ramp screw was tightened, the ramp bolting point was fitted during

moving to the disk and the ramp edge was pushed farther to the outer radius track causing the lower track zero.



a. The interaction plot AC b. The interaction plot BC
Fig.6. Interaction plots of significant factors

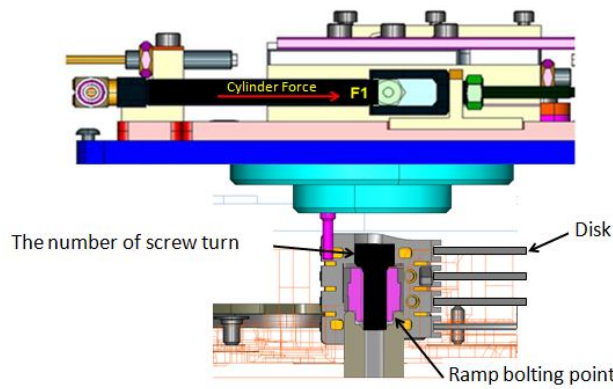

Fig.7. Interaction effect between number of screw turn and cylinder force

The BC interaction plot (Fig. 6b.) showed the interaction between the rotating pin height (B) and the cylinder force (C).

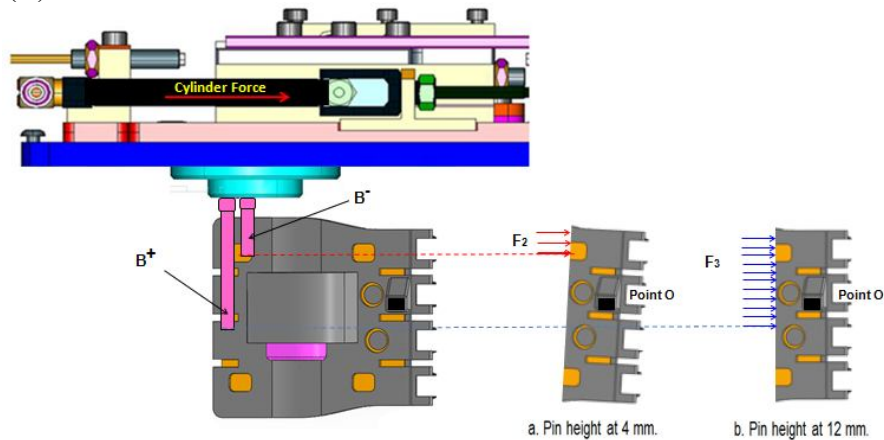

Fig.8. Interaction effect between the rotating pin height and the cylinder force

If the pin height was at 4 mm. (B^-), when cylinder force increased from 2.0 to 8.0 lbs, the track zero was increased from 17,135 to 17,388 tracks. The reason was that when the pin height was at 4 mm. it was far above the fulcrum point O as shown in Fig. 8a. Thus, when the force was applied to the ramp, the ramp was tilt and then tilted more when subjected to a higher force. Unlike when the pin height is

at 12 mm. (B^+), the track zero response was decreased from 15,826 to 15,490 tracks when the cylinder force increased from 2.0 to 8.0 lbs. The reason was that at the pin height of 12 mm. the cylinder force (F_3) was applied passing through the fulcrum point O as shown in Fig. 8b. The ramp feature had a good alignment and was pushed farther to the outer radius track resulting in the lower track zero.

Table 4 showed that the curvature effect tested by the center points was also statistically significant. The center point setting yielded the minimum track zero at 15,217 tracks. The reason was that at this setting the ramp aligned almost vertically and provided smooth rotation.

The half fractional factorial experiment with center points can be used for factor screening purpose but not for determining the optimum setting of assembly process parameters. The screening experiment reduced the number of factors from six to only three significant variables (A, B, and C). Further experiment has to be performed to determine the optimal parameter setting.

Table 4
Analysis of Variance for track zero screening experimental data

Source	DF	Sum of Square	Mean Square	F	P - Value
Number of screw turn (A)	1	2830097	2830097	10.09	0.002
Rotating pin height (B)	1	61720319	61720319	220.13	<0.0001
Cylinder force (C)	1	40632	40632	0.14	0.704
Number of screw turn *Cylinder force (AC)	1	5149950	5149950	18.37	<0.0001
Rotating pin height *Cylinder force (BC)	1	2087125	2087125	7.44	0.008
Curvature	1	3395807	3395807	12.11	0.001
Residual Error	93	26076032	26076032		
Lack of Fit	2	366142	183071	0.65	0.525
Total	99	101299962			

4.4 Improve Phase

In the improvement phase, the Response Surface Methodology (RSM) was applied to determine suitable factor levels that offer the minimum track zero. The Box-Behnken design is an independent quadratic design in that it does not contain an embedded factorial or fractional factorial design (Montgomery, 2006). In this experimental design, the treatment combinations were at the midpoints of edges of the process space and at the center. This design was rotatable and required three levels of each factor. The three factors that were investigated further were shown in Table 5.

Table 5
Process parameters and experimental levels in the Box–Behnken design

Symbol	Factor	Unit	Level of Factor		
			Low	Center	High
A	Number of screw turn	round	0.25	0.75	1.25
B	Rotating pin height	mm.	4.0	8.0	12.0
C	Cylinder force	lbs	2.0	5.0	8.0

The Box- Behnken experimental design consisted of 15 treatment combinations with three levels that were conducted in developing the mathematical model of the relationship between the track zero response and the experimental factors, which were number of screw turn, rotating pin height, and cylinder force. Then, the mathematical model was solved for the optimal setting of factors that yielded the minimum track zero.

All 15 runs were done in random order and all observations were collected for the statistical analysis. Table 6 presented the results of the analysis of variance (ANOVA). At the significance level of 0.05, it was concluded that the linear, square and interaction terms of the model were statistically significant.

Table 6
Analysis of Variance for the track zero response surface model data

Source	DF	Sum of Square	Mean Square	F	P - Value
Regression	7	1843683	263383	20.53	< 0.0001
Linear	3	231006	77002	6.00	0.024
Square	3	1188876	396292	30.89	< 0.0001
Interaction	1	423801	423801	33.03	0.001
Residual Error	7	89818	12831		
Lack of Fit	5	79444	15889	3.06	0.264
Total	14	1933501			

Next, the backward regression was performed in order to find the mathematical model of the relationship between the response and the experimental factors. The mathematical model was shown in Eq. 1. The R²(adj) of 90.71% of the regression model showed that the model can explain 90.71% of the variability in the data. Thus, this model was good enough to predict the relationship between the track zero and the factors.

$$Y = 14815 + 35X_A + 117X_B - 118X_C + 143X_A^2 + 217X_B^2 + 532X_C^2 + 326X_A X_C \tag{1}$$

where

- Y = the response of track zero
- X_A = the coded value of number of screw turn
- X_B = the coded value of rotating pin height
- X_C = the coded value of cylinder force

Then, the mathematical model was solved to obtain the optimal levels of the factors that yield the minimum track zero. Fig. 9. showed that it was predicted that the minimum track zero of 14,800 tracks could be obtained by setting the number of screw turn at 0.60 round, the rotating pin height at 7 mm., and the cylinder force at 5 lbs.

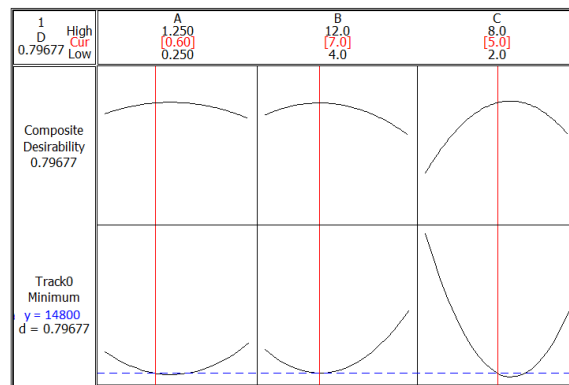

Fig. 9. The response optimizer analysis for the track zero

4.5 Control Phase

This was the final phase of the Six Sigma approach. The confirmatory experiment was performed to ensure that the track zero performance was significantly improved. Table 7 showed the results from the hypothesis testing that the track zero based on the new condition setting was significantly lower than the baseline track zero at the significance level of 0.05. Thus, this test confirmed that the new condition setting was effective to improve the track zero performance.

Table 7
Hypothesis testing results for comparing track zero before and after improvement

	N	Mean	Standard Deviation	SE Mean
Baseline	5740	16185	1116	15
New condition	2465	15120	633	13

Difference = μ (Baseline) – μ (New condition)
 Estimate for difference : 1065.1
 95% CI for difference : (1026.9 , 1103.2)
 T- Test of difference : T- Value = 54.69 P – Value < 0.0005

Moreover, a control plan shown in Table 8 was set up to ensure that the track zero performance after improvement was sustained. The significant process factors, which were the number of screw turn, the rotating pin height, and the cylinder force, were controlled with check sheets every six hours. The track zero was monitored using the X bar - S charts as shown in Fig.10. to detect the special cause variation in the process.

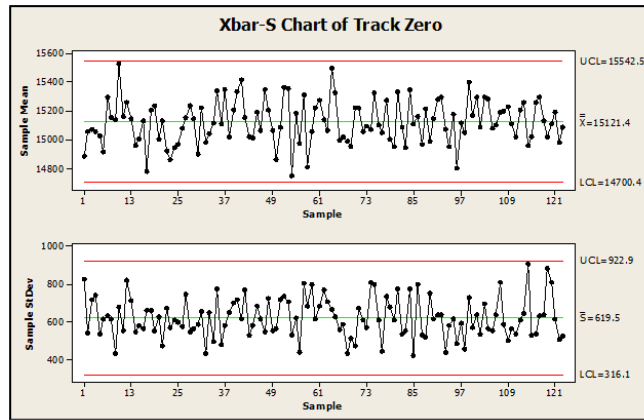

Fig. 10. The X bar – S charts for track zero response

After the implementation, the rate of defective was decreased from 51,929 to 200 DPPM and the process capability index (Ppk) was increased from 0.54 to 1.52. Fig.11 showed the comparative track zero results before and after improvement. It can be seen that the mean track zero and the variation were significantly decreased.

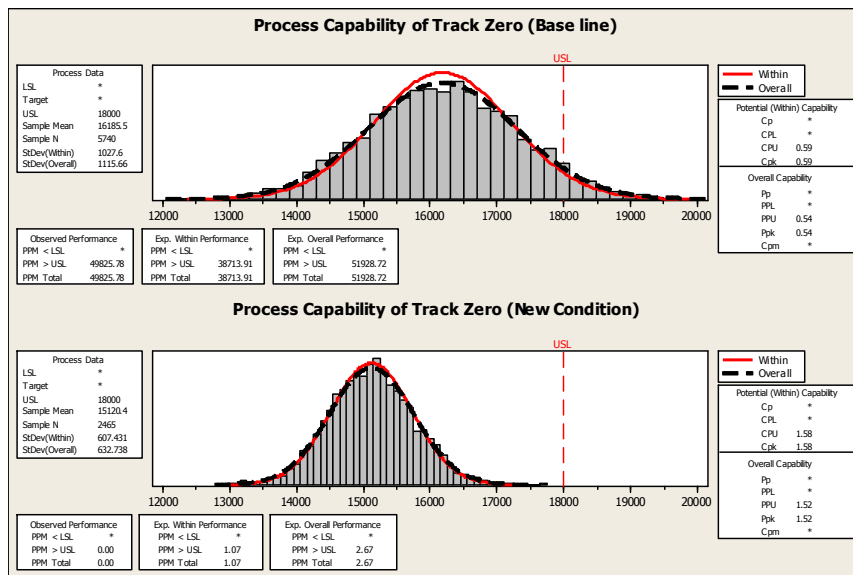

Fig. 11. Comparative process capability before and after improvement

5. Conclusion

This paper presents the methodology to increase the read/write area of hard disk drives by finding an optimal machine setting which minimizes the track zero. This research applied the improvement steps

of the Six Sigma approach, which consists of five phases. Firstly, in the Define phase the problem, the objectives, and the scope of the project were identified. In the Measure phase, the gage repeatability and reproducibility analysis and the process capability analysis were performed. Then, the potential causes of the track zero problem were brainstormed and prioritized by using the Cause & Effect Matrix. Next in the Analyze phase, the design of experiment (DOE) technique with a 2^{6-1} fractional factorial design was used to screen for significant causes of the track zero mean. In the Improve phase, the Box-Behnken experimental design was applied to determine the suitable factor levels that offer the mean of the responses closest to target. It was found that to minimize the track zero mean, the assembly machine should be set at the number of screw turn of 0.60 round, the rotating pin height at 7 mm., and the cylinder force at 5 lbs. Finally in the Control phase, the control plan was set up to monitor responses and control the key process input variables.

Table 8
Control plan to monitor process factors

Process	Monitor items	Control Plan				Responsible	Action Plan
		Spec	Trigger	Frequency	Control Method		
Ramp screw remove	Number of screw turn	0.6 turn	+/- 0.1 turn	Every 6 hours	Check Sheet	Maintenance Technician	Stop production and notify shift supervisor to adjust with gauge tool.
Ramp rotation	Rotating pin height	7 mm.	+/- 1 mm	Every 6 hours	Check Sheet	Maintenance Technician	Stop production and notify shift supervisor to adjust with gauge tool.
Ramp rotation	Cylinder Force	5 lbs	+/- 0.5 lbs	Every 6 hours	Check Sheet	Maintenance Technician	Stop production and notify shift supervisor to adjust with gauge tool.
Mechanical Testing	Track zero	<18000	More than 17500 tracks	Each 20 pcs/batch	X bar – S chart	Production Control	Notify Test Engineer and investigate root causes.

After the implementation of the new condition setting, the process capability index (Ppk) of the track zero was improved to 1.52. The company could save the cost by 1,259,332 baht per month.

References

- Antony, J., Kumar, M., & Tiwari, M. (2005). An application of Six Sigma methodology to reduce the engine overheating problem in an automotive company. *Journal of Engineering Manufacture*, 219, 633-646.
- Does, R., Heuvel, E., & Mast, J. (2002). Comparing nonmanufacturing with traditional application of Six Sigma. *Journal of Quality Engineering*, 15, 177-182.
- Jiguang, W., Nannan, Z., & Yifeng Z. (2012). High performance and high capacity hybrid shingled-recording disk system. *IEEE International Conference on Cluster Computing*. Beijing, China, Sep 24-28.
- Kim, K.H., Lee, Y., & Yang, H. (2009). Ramp tolerance analysis considering geometric errors. *IEEE Transactions on Magnetics*, 45, 2284-2287.
- Klefsjö, B., Wiklund, H., & Edgeman, R.L. (2001). Six Sigma seen as a methodology for total Management. *Measuring Business*, 5, 31-35.
- Kotz, S., & Lovelace, C.R. (1998). *Process Capability Indices in Theory and Practice*, Arnold, New York.
- Kumar, U., Nowicki, D., & Verma D. (2008). On the optimal selection of process alternatives in a Six Sigma implementation. *International Journal of Production Economics*, 111, 456-467.

- Lee, H.S., Kim, Y.H., & Hwang T.Y. (2005). VCM design to improve dynamic performance of an actuator in a disk drive. *IEEE Transactions on Magnetics*, 774-778.
- Montgomery, D. C. (2006). *Design and analysis of experiment*, IV Edition. NY:John-Wiley & Sons, New York.
- Pyzdek, T. (2003). *The Six Sigma handbook revised and expanded*. McGraw-Hill.
- Raisinghani, M.S., Ette, H., & Pierce R. (2005). Six Sigma: concepts, tools, and applications. *Industrial Management & Data System*, 105, 491-505.
- Shen, H., & Wan, H. (2009). Controlled sequential factorial design for simulation factor screening. *European Journal of Operational Research*, 198, 511-519.
- Suk, M., & Albrecht, T.R. (2002). The evolution of load/unload technology. *Microsystem Technologies*, 8, 10-16.
- Takaishi, K., Uematsu, Y., & Yamada, T. (2003). Hard disk drive servo technology for media-level servo track writing. *IEEE Transactions on Magnetics*, 39, 851-856.
- Wong, W., Feng, L., & Guo, G. (2003). Implementation of a Servo Positioning System on Spin Stand. *The 29th Annual Conference of the IEEE Industrial Electronics Society*. Roanoke, United states, Nov 2-6.