

## Impact damage simulation in elastic and viscoelastic media

Seyed Mohammad Navid Ghoreishi\* and Seyed Majid Pourhosseini

*Faculty of Mechanical Engineering, K.N.Toosi of Tech, Tehran, Iran*

### ARTICLE INFO

#### Article history:

Received January 20, 2013

Received in Revised form

July, 2, 2013

Accepted 11 July 2013

Available online

12 July 2013

#### Keywords:

*Elastic material*

*Viscoelastic material*

*Impact*

*Damage*

*Composite*

*Finite element analysis*

### ABSTRACT

Collide of two objects or impact, is one of the main damage initiation reasons. In this paper, impact and damage behavior of elastic and visco-elastic bodies are investigated numerically using the finite element analyses. The results showed that visco-elastic materials, distribute stresses to the edge of model after the impact with a solid body. Furthermore, the impact of elastic and visco-elastic composite materials are analyzed and the variations of stress, displacement, damage energy and the damage patterns during a time period are compared for the two material models. The reduction in the values of stress, displacement and damage energy of visco-elastic material is also determined relative to the elastic composite material.

© 2013 Growing Science Ltd. All rights reserved.

## 1. Introduction

Impact loading or high speed collide of bodies is one of the main reasons for occurring the overall failure or damage of engineering materials and component. For example, impact of very small particles with great velocities to the fuselage of airplanes can affect noticeably the reliability and safe operational conditions of aero space structures. Therefore, it is necessary to study the behavior of materials and structures and the damage induced under high speed loading conditions such as impact and shock loading. Damage in ductile materials occurs mainly due to the extensive continuous plastic deformations which decreases the load bearing capacity of materials. From physical point of view, damage can occur because of the reduction in the nominal cross-sectional area of a given reference volume element (RVE) as a result of nucleation and growth of micro-cavities, micro-cracks and etc. McClintock (1968) recognized the role of cracks and micro-voids in ductile damage and tried to correlate the radius of nucleated cavities to the plastic strain increment. Rice and Tracey (1969) provide a numerical model for nucleation of very small spherical voids in elastic-perfectly plastic

\* Corresponding author.

E-mail addresses: [navid\\_ghoreishi@yahoo.com](mailto:navid_ghoreishi@yahoo.com) (S. M. N. Ghoreishi)

materials. But they ignored the effects of strain hardening and interaction between micro-voids in their model. Bacon and Brun (2000) defined a methodology for Hopkinson test in a non-uniform visco-elastic bar. Mechanical impedance of the two elastic and visco-elastic bars was obtained from transfer matrix and validated experimentally. Lin and Schomburg (2003) proposed a finite elastic–viscoelastic–elastoplastic material law for damage analysis. They developed a visco-elastic model based on an energy dissipation simulation and then they verified the proposed model with theoretical and numerical studies. Assie et al. (2010) modeled low velocity impact and contact of visco-elastic materials using the finite element method (FEM). However, the mentioned papers have been studied the impact damage phenomenon only for isotropic materials and damage analysis of anisotropic (e.g. composite) or visco-elastic materials has been rarely investigated in the past. Among the few research studies performed in this field, Pavan et al. (2010) developed a model for anisotropic visco-elastic damage in composites and tried to formulate damage properties of visco-elastic materials according to the relationship between elastic and visco-elastic properties.

In this paper, following a brief description of damage phenomenon, the impact damage of visco-elastic and elastic and visco-elastic composite materials are investigate numerically using finite element analyses and their responses under the impact loading are compared.

## 2. Visco-elastic materials

Damping is an important parameter for predicting the dynamic response of engineering structures. The damping analysis of structures needs a suitable theory or criterion to explain the capability of material for absorbing and dissipating the applied energy to the components. In visco-elastic materials, the mechanical and physical properties are time dependent. Creep and relaxation are two characteristics of these materials. Strain relation for creep is explained by the following general equation:

$$\varepsilon(t) = \varepsilon_U + (\varepsilon_R - \varepsilon_U) \left[ 1 - \exp\left(-\frac{t}{\tau}\right) \right] \quad (1)$$

where  $t$ ,  $\tau$ ,  $\varepsilon(t)$ ,  $\varepsilon_U$  and  $\varepsilon_R$  are time, time constant, total strain, unreleased strain and released strain, respectively. Stress,  $\sigma$ , is also expressed as:

$$\varepsilon(t) = D(t)\sigma \quad (2)$$

In Eq. (2),  $D(t)$  is the creep modulus which depends on the time and is defined by:

$$D(t) = D_U + (D_R - D_U) \left[ 1 - \exp\left(-\frac{t}{\tau}\right) \right], \quad (3)$$

where  $D_R$  is the released modulus of creep and  $D_U$  is the unreleased modulus. The stress-strain relationship for relaxation is:

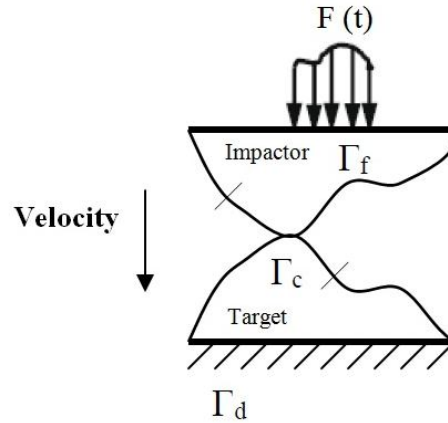
$$\begin{aligned} \varepsilon(t) &= D(t)\sigma, \\ E(t) &= E_U + (E_R - E_U)\exp\left(-\frac{t}{\beta}\right), \end{aligned} \quad (4)$$

where  $E(t)$  is the relaxation modulus of stress which contains two parts: the modulus of released system ( $E_R$ ) and the modulus of unreleased system ( $E_U$ ).  $\beta$  is also the total energy release time.

### 2.1. Impact and contact in visco-elastic materials

Impact response of visco-elastic materials differs from elastic materials since the damping properties and the stress-strain relationships vary with time in visco-elastic materials. Consider two visco-elastic bodies shown in Fig 1 where the boundary of each body consists of three parts:  $\Gamma_d$ ,  $\Gamma_f$  and  $\Gamma_c$ . While

$\Gamma_c$  defines the contact zone,  $\Gamma_f$  shows the traction free portions of the boundaries in both bodies. Impact response of these materials depends on the geometry, the initial velocity and the material properties and consequently solving such a nonlinear initial value problem is difficult in general.



**Fig. 1.** Impact of two visco-elastic bodies

Dynamic equation of motion is explained by:

$$\sigma_{j,i,j} + b_i = \rho \ddot{u}_i \quad (in \Omega) \quad (5)$$

where  $\Omega$ ,  $\rho$ ,  $b$ ,  $u$  and  $\ddot{u}$  are the boundary of body, density, body force, displacement and the acceleration, respectively. Constitutive equation of visco-elasticity can be also written as:

$$\sigma_{ij}(X_k, t) = \int_{-\infty}^t Q_{ijkl}(t - \tau) \frac{\partial \varepsilon_{kl}(X_k, t)}{\partial \tau} d\tau \quad (in \Omega), \quad (6)$$

where  $Q$  is the released energy modulus. By substituting Eq. (6) into Eq. (5), equation of motion for visco-elastic materials is derived.

### 3. Damage in ductile materials

Damage is generally categorized into three types:

1. Sudden fracture and rupture
2. Damage in porous plastics and
3. Continuum damage mechanics (CDM)

For the CDM type damage, an internal damage variable,  $D$ , is defined based on a thermodynamically irreversible process which was developed by Bonora (1997). In order to define a damage model, first the development of energy dissipation in the materials should be known. The damage variable ( $Y$ ) is determined by differentiating the potential function of dissipated energy. This function depends on the type of material and for any material a unique potential function is obtained. Moreover, triaxiality of stresses at the onset of damage should be considered.

Damage reduces the load bearing capacity of materials via the initiation and coalescence of cracks inside the damage zone (or by reduction of the area subjected to sudden impact loading). The damage tensor  $D$  defined by Bonora et al. (2005) is usually used for estimating the damaged area.

$$D = 1 - \frac{A_{eff}}{A_0}, \quad (7)$$

where  $A_0$  and  $A_{eff}$  are the initial (i.e. before impact) and the effective (i.e. after impact) cross-section

areas, respectively. For anisotropic materials, the damage tensor ( $D$ ) is usually obtained using experimental methods. Damage potential function is defined as:

$$f = f_p(\sigma, R, X, D) + f_D(Y, p, D), \quad (8)$$

where  $f_D$ ,  $p$ ,  $Y$ ,  $R$  and  $\sigma$  are potential function of energy dissipation, plastic strain, damage variable, hardening function and stress, respectively. Bonora (1997) suggested damage parameter as expressed in Eq (9):

$$f_D = \left[ \frac{1}{2} \left( -\frac{S_y}{S_0} \right)^2 \frac{S_0}{1-D} \right] \frac{(D_{cr} - D)^{\frac{(\alpha-1)}{\alpha}}}{P^{\frac{(2+n)}{n}}} \quad (9)$$

where  $D_{cr}$ ,  $S_0$ ,  $n$ ,  $S_y$  and  $\alpha$  are critical value of damage variable, constant of materials, power of strain, yield strength and damage exponential, respectively.

After a brief description of the damage phenomena and its basic relations, the damage behavior of some materials subjected to impact loading is investigated numerically in the out coming sections. Due to the complexity of associate problems with impact damages, theoretical models or methods are very difficult to use for predicting the damage response of structures. However, the use of numerical approaches such as finite element analyses is more suitable for dealing with these problems.

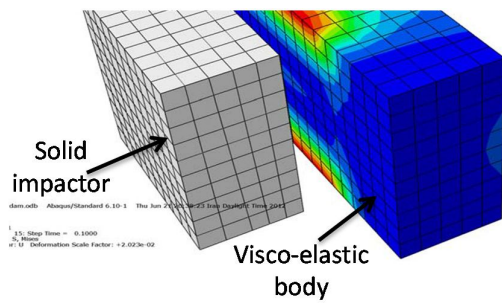
#### 4. Numerical simulation of impact in visco-elastic materials

In order to simulate a typical damage case, the impact of a solid body (as impactor) with a cubic component of dimensions 300mm×200mm×80mm made of a visco-elastic material is investigated numerically. Table 1 presents the material properties and the creep and relaxation constants of the selected material. The Prony series in the time domain with step of 0.2s was used for modeling the material. For analyzing the impact of two bodies, the mentioned cubic specimens were modeled in the ABAQUS finite element code. This code is powerful software for numerical analyses of a wide range of engineering problems such as impact of visco-elastic materials. The visco-elastic body was modeled using C3D8R cubic solid elements and the properties presented in Table1. Then a solid indenter with initial velocity of 50 m/s was impacted to the visco-elastic material and by performing a nonlinear time-dependent stress analysis, the distributions of induced stresses during the impact was obtained for the entire model. Fig. 2 shows the contour of von Mises stress for the investigated visco-elastic body after the impact. As seen from this Figure, the stresses are damped to the corners of the visco-elastic material because of the damping property of the visco-elastic body.

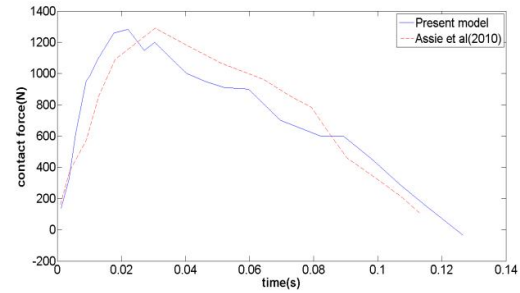
**Table 1.** Material properties of the visco-elastic body.

Young modules (GPa)	Poission ratio	Density ( $\frac{\text{kg}}{\text{m}^3}$ )	Creep coefficient	Relaxation coefficient
150	0.3	3000	0.3	0.4

In order to validate the obtained finite element results, the variations of contact forces for the visco-elastic body of this research was compared with the numerical results of the same body reported by Assie et al. (2010). For this purpose, the values of contact forces applied to the central element of target object in the time period of 0 to 0.14s have been compared for both models in Fig 3. The good agreement that exists between the two curves, shows the validly of the finite element model and analysis of this research for simulating the impact problem.



**Fig. 2.** Contour of von Mises Stress distribution after impact in the investigated visco-elastic material

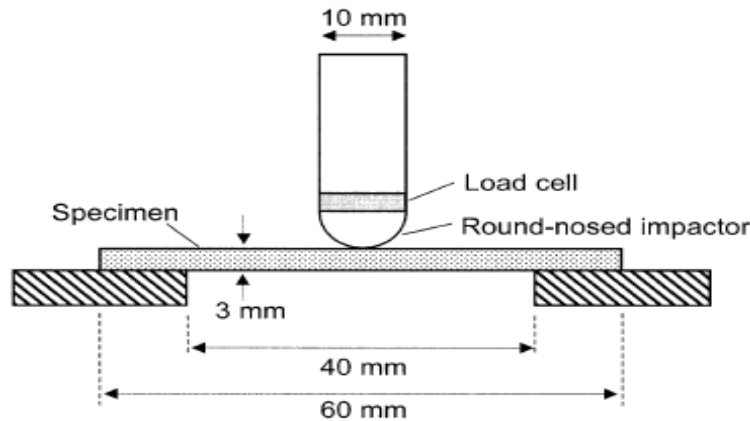


**Fig. 3.** Comparison of contact force in two models

In order to validate the obtained finite element results, the variations of contact forces for the visco-elastic body of this research was compared with the numerical results of the same body reported by Assie et al. (2010). For this purpose, the values of contact forces applied to the central element of target object in the time period of 0 to 0.14s have been compared for both models in Fig 3. The good agreement that exists between the two curves, shows the validity of the finite element model and analysis of this research for simulating the impact problem.

### 5. Damage analysis for elastic and visco-elastic composite materials

In this section, damage in elastic and visco-elastic composites is simulated using the ABAQUS code. Fig. 4 shows the schematic of a simply supported composite sheet subjected to impact loading. This configuration of loading has also been used by Bonora et al. (2005) to study the damage process.



**Fig. 4.** Impactor and composite sheet (Bonora et al. 2005)

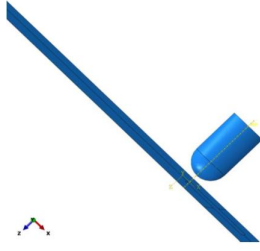
The composite sheet contains 6 symmetric plies with angle of 90,-90 and 0. Other properties are listed in Table 2.

**Table 2.** Characteristics of the composite material

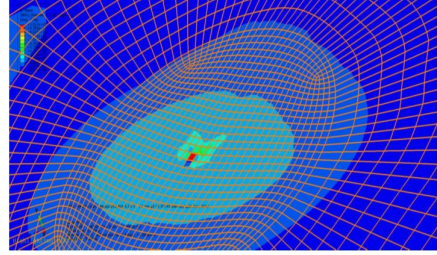
$E_1$ (GPa)	$E_2$ (GPa)	$\nu_{12}$	$G_{23}$ (GPa)	$G_{12}$ (GPa)	$G_{13}$ (GPa)
150	120	0.3	80	80	80

Fig. 5 shows the model of impactor and composite sheet created in the ABAQUS code. The composite sheet was assumed to behave as elastic and visco-elastic material. Thus, first the impact of elastic composite sheet (with elastic properties given in Table 2) was analyzed numerically. Then the same sheet was reanalyzed by considering the composite as a visco-elastic material (with creep and relaxation parameters given in Table 1). The composite sheet was modeled with 3036 S4R shell elements. Figs. 6 and 7 show the patterns of damages obtained for the elastic and visco-elastic

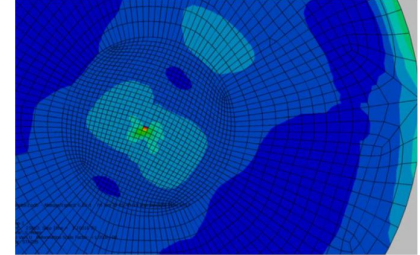
composites, respectively. These damage patterns are similar with the patterns reported in Dear and Brown (2003). In both models it is observed that the damage initiates from the target element which collide with the tip of impactor. As expected, damage propagation in visco-elastic model is less than elastic one because of damping properties.



**Fig. 5.** Three dimensional model of compactor and composite sheet created in the ABAQUS code

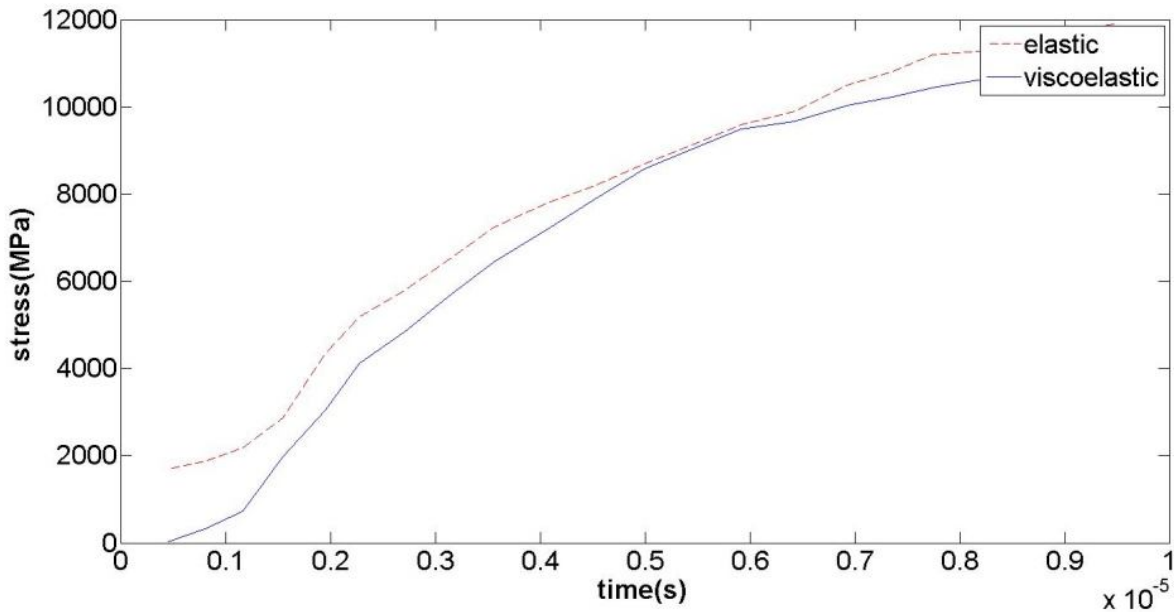


**Fig. 6.** Damage pattern in elastic composite sheet after the impact

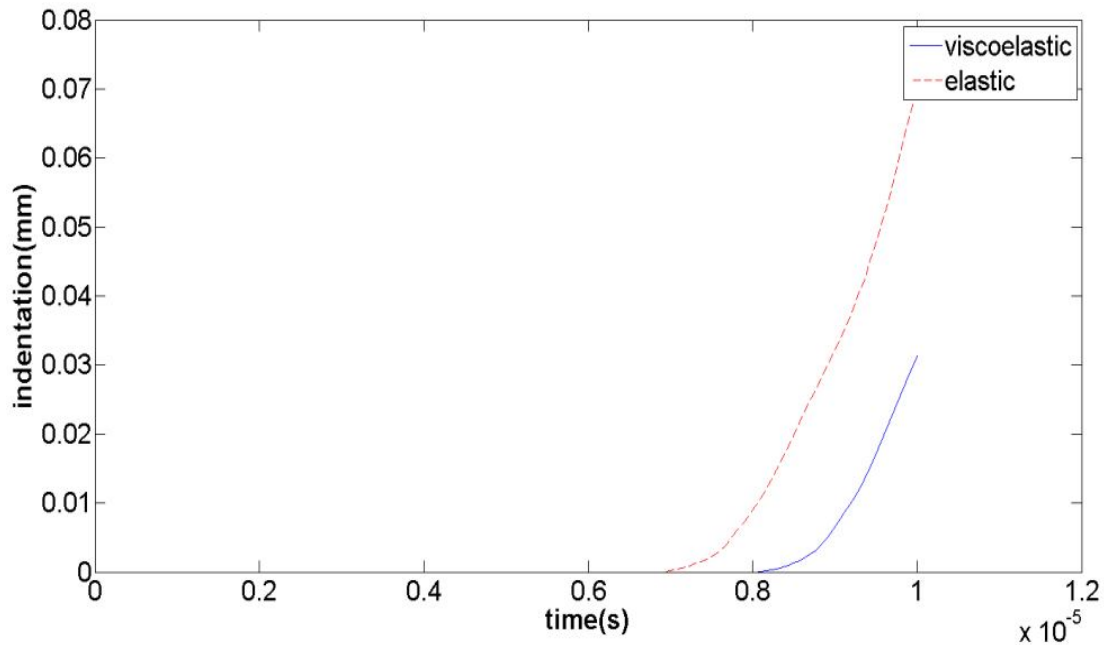


**Fig. 7.** Damage pattern in visco-elastic composite sheet after the impact

Fig 8 compares the variations of stress with time obtained from a typical reference element in both elastic and visco-elastic models. As expected, this Figure reveals that the stresses in elastic model are higher than the visco-elastic material, which is mainly due to the influence of damping properties of the visco-elastic materials. For example, at  $t = 1 \times 10^{-5}$  s the values of stresses for the given element are 1106 MPa and 1200 MPa, respectively for the elastic and visco-elastic materials that shows an increase of about 8 % in the value of elastic stress in comparison with the visco-elastic stress. Similarly, the displacement variation for the investigated element has been shown versus time for both elastic and visco-elastic composite materials in Fig. 9. This Figure indicates the noticeable influence of material type on the value of displacement field when the body is subjected to impact loading. Actually, one part of energy is dissipated to overcome the spring and dashpot displacement in visco-elastic model. However in elastic materials, the entire force should overcome only the spring displacement. According to Fig 9 at time  $1 \times 10^{-5}$  s the elastic indentation is about 0.072 mm which is approximately 1.25 times the corresponding value of visco-elastic indentation (i.e. 0.032 mm).

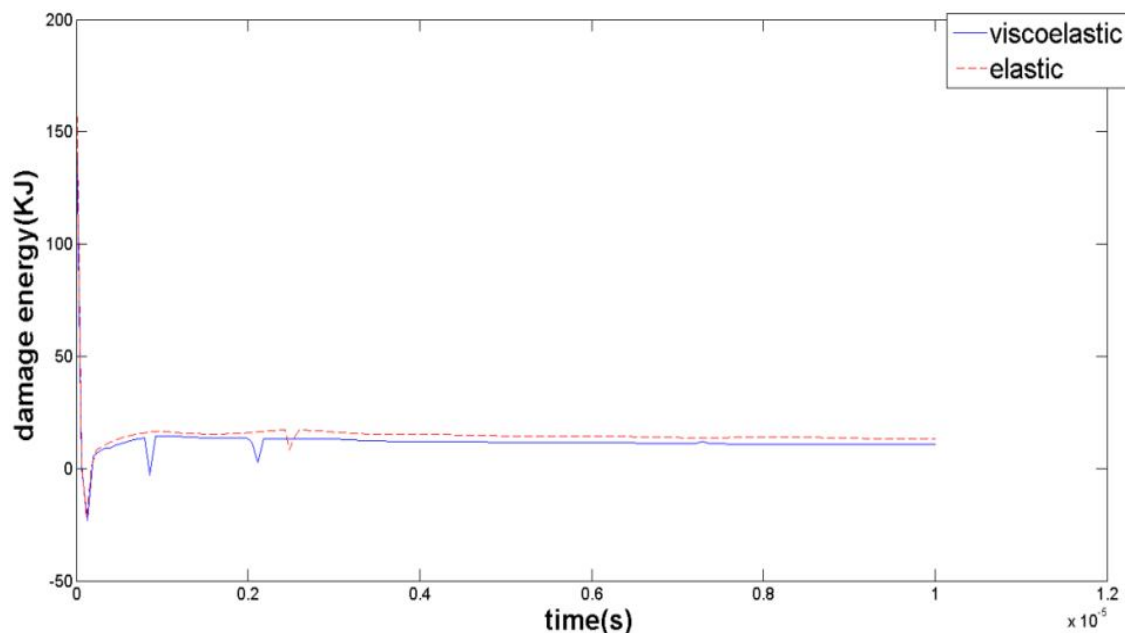


**Fig. 8.** Variations of stress (for a given reference element) with time for both elastic and visco-elastic composite materials



**Fig. 9.** Variations of displacement (for a given reference element) with time for both elastic and visco-elastic composite materials

Fig 10 also compares the damage energies (i.e. the energy required for a same damage in two bodies) obtained from the finite element analyses of both elastic and visco-elastic models. Again at time  $t = 1 \times 10^{-5} s$  damage energy for visco-elastic and elastic models are about 10.6 KJ and 13.3 KJ, respectively. The elastic damage energy for this case is about 25 % more than the visco-elastic composite material, which is in agreement with the previous discussion. Consequently, resistance of visco-elastic materials against the damage initiation and propagation is more than the elastic materials because of damping effects. Hence, the visco-elastic materials are usually used as good impact absorbers in the engineering and industrial applications.



**Fig. 10.** Comparison of damage energies for both elastic and visco-elastic composite materials subjected to impact loading

## 6. Conclusions

In this paper, impact and damage in viscoelastic materials was studied using the finite element analysis. First, contact forces induced from impact on visco-elastic materials was validated by Assie et al. (2010). It was demonstrated that the contact stresses are transferred to the edges of visco-elastic target. As expected, because of damping properties of materials, load bearing capacity of target was more than the elastic model. This can be considered as an advantage for visco-elastic materials with respect to the elastic ones when they are subjected to impact or shock loads. By comparing the impact response of an elastic composite sheet with visco-elastic composite sheet, it was shown that the visco-elastic properties of materials improve the ability and resistance of such materials against damages induced by impact loading. The results of this research in conjunction with the similar studies published by Dear and Brown (2003), Bonora et al. (2005) and FEM analyses of Lin and Schomburg (2003) suggest that visco-elastic materials are suitable candidate materials as load absorbers in critical industries.

## Reference

- Assie, A. E., Eltaher, M. A., & Mahmoud, F. F. (2010). Modeling of viscoelastic contact-impact problems. *Applied Mathematical Modelling*, 34(9), 2336-2352.
- Bacon, C., & Brun, A. (2000). Methodology for a Hopkinson test with a non-uniform viscoelastic bar. *International journal of impact engineering*, 24(3), 219-230.
- Bonora, N. (1997). A nonlinear CDM model for ductile failure. *Engineering Fracture Mechanics*, 58(1), 11-28.
- Bonora, N., Gentile, D., Pironi, A., & Newaz, G. (2005). Ductile damage evolution under triaxial state of stress: theory and experiments. *International Journal of Plasticity*, 21(5), 981-1007.
- Dear, J. P., & Brown, S. A. (2003). Impact damage processes in reinforced polymeric materials. *Composites Part A: Applied Science and Manufacturing*, 34(5), 411-420.
- Lin, R. C., & Schomburg, U. (2003). A finite elastic-viscoelastic-elastoplastic material law with damage: theoretical and numerical aspects. *Computer methods in applied mechanics and engineering*, 192(13), 1591-1627.
- McClintock, F. A. (1968). A criterion for ductile fracture by the growth of holes. *Journal of Applied Mechanics*, 35, 363.
- Pavan, R. C., Oliveira, B. F., Maghous, S., & Creus, G. J. (2010). A model for anisotropic viscoelastic damage in composites. *Composite Structures*, 92(5), 1223-1228.
- Rice, J. R., & Tracey, D. M. (1969). On the ductile enlargement of voids in triaxial stress fields. *Journal of the Mechanics and Physics of Solids*, 17(3), 201-217